

# THE STORY OF THE MOOSE

**Ritual of the Loyal Order of Moose**



*Originally adopted at the Convention of the  
Supreme Lodge at Uniontown, Pennsylvania, 1908  
and revised from time to time.*

---

*Issued by the Ritual Department as Authorized by the  
Supreme Council*

---

**KEY TO FLOOR POSITIONS****Diagram No.1**

1. Prelate's position is in center of Altar, with toes within one (1) foot of Altar to open the Bible.  
Position 1 area - 12-18 inches from Altar and centered for Prayer.
2. Three (3) feet centered in front of Governor's station on line of march.
3. Orator's chair three (3) feet left of Governor's station with front edge of chair in line with back edge of Governor's station.
4. Prelate's station.
5. Jr. Governor's station.
6. Past Governor's station in line with front edge of Jr. Governor's station and left side of station in line with front edge of Governor's station.
7. Sergeant-at-Arm's chair three (3) feet right of Governor's station with front edge of chair in line with back edge of Governor's station.
8. Position of all staff members when delivering their charges to class unless otherwise instructed. Back five (5) feet and as wide as standard Altar (32") toes within limits.
9. Chairs for staff, for exit with Past Governor's and Sergeant-at-Arms chairs splitting the line of march in front of Governor's station.
10. Flag seven (7) feet right of Governor's chair.
11. Class - Lodge enrollment, chairs four (4) feet from Altar and centered. (For competition - two (2) chairs, four (4) feet from Altar and centered, and three (3) feet apart.)  
Lodge meeting without enrollment - member seating area, and as large as needed.
12. Area for Family seating (Not for competition).
13. Optional State, Provincial or National Flag (Not for Competition).

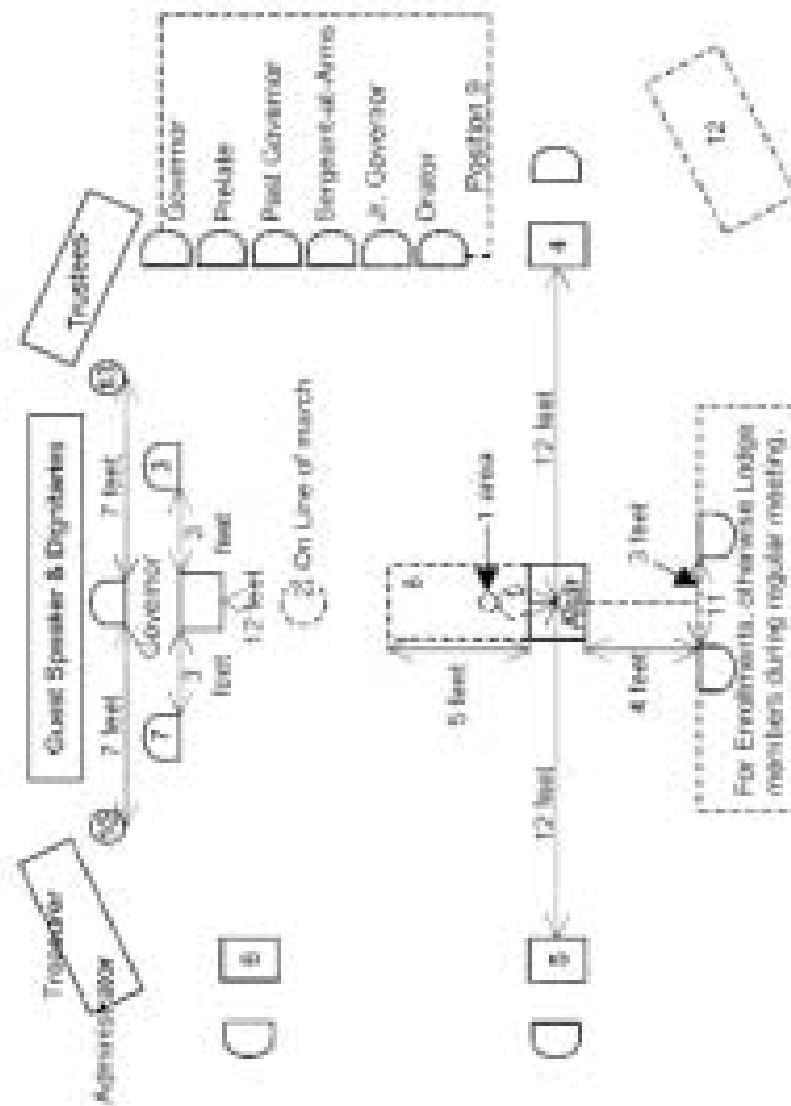

DIAGRAM NO. 1

---

## TABLE OF CONTENTS

Floor Positions .....	2
Diagram No. 1.....	3
<b>LODGE MEETING</b> .....	<b>5</b>
General Instructions for Lodge Meeting.....	5
Opening Ceremony .....	8
Official Visit .....	9 & 17
Order of Business .....	10-12
Nine O'clock Ceremony .....	11
<b>ENROLLMENT CEREMONY</b> .....	<b>14</b>
Special Instructions .....	15
<b>INSTRUCTIONS FOR SPECIAL MEETINGS</b>	
Openings .....	16
Enrollment Ceremonies held in Conjunction with Lodge Meeting.....	18
<b>INSTRUCTIONS FOR SPECIAL MEETINGS</b>	
Closing .....	27
Diagram No. 2.....	28
Floor Positions .....	29
Floor Movements .....	30
Gestures.....	32
Attention and Speaking.....	33
Individual Instructions .....	34
Rules of Ritual Competition.....	38
<b>SERVICE OF TRIBUTE</b> .....	<b>46</b>
Diagram No. 3.....	46
<b>SPECIAL GRAVESIDE SERVICE</b> .....	<b>50</b>
<b>MEMORIAL SERVICE</b> .....	<b>52</b>
Diagram No. 4.....	56
<b>INSTALLATION CEREMONY</b> .....	<b>57</b>
Diagram No. 5.....	58
<b>MOOSEHEART FOUNDER'S DAY CEREMONY</b> ..	<b>69</b>

---

## **LODGE MEETING**

### **INSTRUCTIONS FOR PREPARING LODGE ROOM**

**LODGE PREPARATION:** Prior to the Lodge meeting, the Sergeant-at-Arms should properly set up the Lodge room, placing stations, Altar, chairs, tables, and flags in their proper location. (Per. Diagram 1, page 3.)

The Sergeant-at-Arms should also properly place the chimes and gavel, and prepare the Altar and stations. The correct station cloth should be placed upon each station. If the Altar cloth has flags, they should be facing the Governor and Class.

The Bible should be elevated. If a regular Bible stand is used, it should be placed to face the Governor so open Bible faces position 1.

If the family members are to be invited into the meeting for the enrollment ceremony, chairs to accommodate them should be set up prior to the meeting, and should be spaced to allow comfortable seating in the designated area, position 12.

### **GENERAL INSTRUCTIONS FOR LODGE MEETING**

All persons, except candidates present for enrollment and qualified family members in attendance at an Enrollment ceremony, will show their official good standing membership card to the Inner Guard upon entry into the Lodge room. The Inner Guard may designate an assistant to check cards of all who have previously entered. Any questions should be reported to the Governor. If a class is to be enrolled, candidates will be seated in position 11 and the Ritual Staff will be seated as directed.

**OPENING:** The Governor shall call the Lodge to order promptly at the appointed hour if a quorum of seven good standing members are present, even though no other officers are present. He shall fill vacancies in the stations by pro tempore appointments. If the Governor is absent, the Junior Governor shall call the Lodge to order. (See General Laws.)

**MEMORIZATION:** All officers, prior to their installation, shall commit to memory their parts in the opening and closing ceremonies. The Lodge should be opened and closed, and the enrollment ceremony conferred without the use of the printed ritual.

**LODGE SESSION:** The Governor may be seated during the business session of the Lodge, or when so instructed, but should stand when speaking or while being addressed. All remarks should be directed to the Governor, unless permission has been granted to address another Brother.

**ADDRESSING OFFICERS:** The officers of the Lodge should be addressed as "Brother" followed by name of their office, as "Brother Governor" or "Brother Administrator." All other members should be addressed as "Brother \_\_\_\_\_." A member desiring the floor will rise, wait to be recognized by the Governor, and address him as "Brother Governor." The Governor will further recognize the member by saying "Brother \_\_\_\_\_", whereupon the member will proceed. When the Governor calls for a report or gives individual instructions, the member being addressed will rise and proceed.

**ORDER:** When, in the opinion of the Governor, any member is guilty of disorderly conduct, he shall be denied the floor and may be reprimanded, fined, or both. If such conduct continues, the offending member may be removed by the Sergeant-at-Arms by order of the Governor. (See General Laws.)

**ADJOURNMENT:** No motion to adjourn shall be entertained by the Governor. The closing ceremony must be concluded in full.

---

**ASSISTANT SERGEANT-AT-ARMS:** When an Assistant Sergeant-at-Arms is needed for a Lodge meeting, he shall be seated at the door to the lodge room.

**INNER & OUTER GUARD:** Seated inside of entry door to Lodge meeting room. (If used by the Lodge)

**PARAPHERNALIA:** Altar and station cloths, officer emblems, and all other Lodge paraphernalia must be obtained from the Supreme Lodge Catalog Sales.

**CHIMES:** Every Lodge must have Nine O'clock Ceremony chimes to be operated by a predesignated officer or member as appointed by the Governor.

**CEREMONY PICTURE:** Every Lodge should have an official Nine O'clock Ceremony picture which must be placed on the wall or corner in the geographical direction of Mooseheart.

**NINE O'CLOCK CEREMONIAL LIGHT:** Every Lodge should be equipped with the official Star Transparency which must be on a separate switch and be located above the Altar. The Inner Guard will be in charge of operating the lighting during a Lodge Meeting. (If used by the Lodge)

**VISITING BROTHERS:** The Governor must satisfy himself that all visiting Brothers are entitled to remain if he allows them to be present at the meeting.

**WEARING OF OFFICERS EMBLEMS:** Officers shall invest themselves with the emblem of their office before the meeting starts. Officers may continue wearing them after the meeting, but shall deposit them for safe keeping in a predesignated place before leaving the building.

Officers are encouraged to wear their emblems of office at all special functions of the Lodge at which it is appropriate to do so.

**OPENING CEREMONY**

GOVERNOR: *(gives one rap)* Under authority granted by the Supreme Lodge, \_\_\_\_\_ Lodge \_\_\_\_\_, Loyal Order of Moose will come to order. Officers will assume their respective stations. The inner door will be closed until otherwise directed. Brother Inner Guard, *(pause while Inner Guard rises)* are all present entitled to remain?

*(Inner Guard will face the Governor, report and be seated. In the case where the lodge does not have an Inner Guard, the Sergeant-at-Arms will perform this task.)*

INNER GUARD: Brother Governor, they are.

GOVERNOR: Brother Administrator, call the roll of officers.  
*(The Administrator rises to call the roll of officers. Each officer will respond if in attendance. If not, the Administrator will note his absence. If any officer is absent, the Governor will make pro-tempore appointments.)*

ADMINISTRATOR: The roll has been called.

GOVERNOR: *(Gives two raps)* Everyone will please rise. The Prelate will open the Bible and deliver the opening prayer.

*(Prelate goes to position 1, faces the Altar, and opens the Bible in a dignified manner.)*

PRELATE: This is the Holy Bible, our inspiration and our guide.

*(Prelate steps back one step into position 1 area to deliver prayer)*

PRELATE: Let us fold our arms and bow our heads.

*(Prelate slowly raises his head and delivers his prayer.)*

PRELATE: Supreme Being, Creator of the universe and Father of all mankind, we give You thanks for our fraternal brotherhood and the great precepts it embodies. Keep us diligent and mindful of our commitments to You, our chil-

dren, our senior members, our families, and our communities. Give us a spirit of peace, harmony and progress as we carry on these precepts in our Lodge, and in our lives. Remind us each day that the greatest good we can do is to serve You through service to our fellow man. Amen.

MEMBERS: Amen.

*(Prelate returns to his station.)*

GOVERNOR: *(U.S. Lodges)* I present the flag of our country *(turns to Flag)*. Place your right hand over your heart and join with me in the Pledge of Allegiance.

### PLEDGE OF ALLEGIANCE

"I pledge allegiance to the flag of the United States of America, and to the Republic for which it stands, one nation under God, indivisible, with liberty and justice for all."

CANADIAN GOVERNOR: I present the flag of our country *(turns to flag)*. Brothers, salute the flag. You will join with me in singing "O Canada."

GOVERNOR: Brothers, I welcome you and declare \_\_\_\_\_ Lodge, \_\_\_\_\_, officially opened.

### LOYAL ORDER OF MOOSE - OFFICIAL VISITOR

*(Used whenever a Supreme Lodge Officer or Representative officially visits a Lodge.)*

GOVERNOR: At this time we are privileged to have \_\_\_\_\_ *(name)* \_\_\_\_\_ *(title)* visiting with us.  
\_\_\_\_\_ *(first name)* welcome to \_\_\_\_\_ Lodge \_\_\_\_\_.

*(Gives one rap and seats Lodge.)*

**ORDER OF BUSINESS**

1. *Reading of minutes of the previous meeting.*
2. *Communications and notices.*
3. *Reports of sickness and distress.*
4. *Ordering of payment for approved bills.*
5. *Applications for membership.*

GOVERNOR: Brother Administrator, do we have any new applications for membership or any applications for re-enrollment?

ADMINISTRATOR: Yes Brother Governor we do. We have \_\_\_\_\_ new applications for membership and \_\_\_\_\_ applications for re-enrollment.

GOVERNOR: Has the Application Review Committee reported favorably on all these applications?

APPLICATION REVIEW COMMITTEE CHAIRMAN: Yes Brother Governor we have.

GOVERNOR: Brother Administrator, please read the names of the applicants and their sponsors.

ADMINISTRATOR: *(Read names of all applicants and names of sponsors.)*

GOVERNOR: We will proceed to vote by the usual voting sign of the Order, unless there is a request to vote by secret ballot.

*(A request can be made from the floor to have a paper ballot instead of the hand vote, or the Governor can also request a paper ballot. Paper ballots shall be available at all times. If a paper ballot is used, the Governor shall appoint a three member election committee to count the ballots and report the results to the Lodge.)*

GOVERNOR: All those in favor of accepting these applicants for membership will vote by using the voting sign of the Order.

GOVERNOR: Those opposed?

GOVERNOR: The vote is favorable, and these applicants have been accepted.

*(If vote is not favorable, additional votes should be taken by dividing applicants until each individual has been accepted or rejected.)*

6. *Reports of Standing and Special Committees.*
7. *Report of Officers Meeting.*
8. *Nine O'clock Ceremony.*

### NINE O'CLOCK CEREMONY

*(At the hour of nine o'clock p.m., wherever Moose are gathered in the name of the Order, they are requested to stand, face toward Mooseheart, fold their arms across their chests, and for a moment bow their heads in silent prayer, repeating in concert the words of the Nine O'clock Ceremony. When enrolling candidates, this ceremony shall be deferred until the Ritual Governor instructs class. At a regular meeting the Governor should call for the ceremony as close to nine o'clock as possible.)*

GOVERNOR: *(Gives two raps)* It is now nine o'clock. At this time the little children at Mooseheart kneel at their beds to say their evening prayers. Let us face toward Mooseheart, *(Governor gestures in the direction of Mooseheart)* fold our arms, bow our heads, and join them in silent prayer.

*(Lights turned low but never off, chimes sounded slowly nine times. After ninth stroke - )*

GOVERNOR: Repeat after me.

GOVERNOR: Let the little children come to me

MEMBERS: *(Repeat)*

GOVERNOR: Do not keep them away

MEMBERS: *(Repeat)*

GOVERNOR: For they are like the kingdom of Heaven

MEMBERS: *(Repeat)*

GOVERNOR: God Bless Mooseheart

MEMBERS: *(Repeat)*

GOVERNOR: Amen.

MEMBERS: *(Repeat.)*

GOVERNOR: Everyone will again face the Altar.

*(Lights turned up.)*

GOVERNOR: *(Gives one rap.)* Please be seated.

GOVERNOR: This Lodge, along with all other units in our Fraternity participates in the building of an Endowment Fund, which we hope will be ample to meet any emergency that may confront Mooseheart or Moosehaven. All members are invited to contribute to this fund in such amount as they desire. The Sergeant-at-Arms will now receive your contributions, and the sum collected will be remitted to Mooseheart so it may be credited to the Endowment Fund.

*(While the contributions are being received, the Governor may call on the Endowment Fund Chairman to announce any current or future Endowment Fund activities.)*

9. *Unfinished Business.*

10. *New Business. (For referral to Officers.)*

11. *Enrollment of Candidates. (Refer to page 14.)*

12. *(Report of Nominating Committee when necessary.)  
(Election or Installation of Officers when necessary.)*

13. *Good of the Order.*

14. *Receipts.*

GOVERNOR: Brother Administrator, give the total sum of money collected by you as Administrator of this Lodge since your last report, and prior to this meeting.

ADMINISTRATOR: I have collected in all the amount of \$\_\_\_\_\_.

GOVERNOR: Brother Treasurer, have you received bank deposit slips from the Administrator showing the amount of \$ \_\_\_\_\_ deposited to the credit of this Lodge?

TREASURER: I have, *(or)* I have not *(as the case may be.)*  
*(If the Treasurer has not received the proper deposit slips from the Administrator, the matter shall be adjusted at once.)*

*(The Governor will give two raps, Officers will move to front of their stations or tables to form the Defending Circle.)*

GOVERNOR: Let us remain in place completing the Defending Circle of our Order. *(If a member has died since the last meeting, the Governor will say)* Brothers, since our last meeting, our lives have been diminished by the loss of *(announce name or names)*. His *(or their)* passing leaves our ranks emptier, but our memories richer. I ask you to remember him and his many virtues as we stand in silence with arms folded and heads bowed. *(Pause)* May he rest in peace.

MEMBERS: Amen.

GOVERNOR: Brother Sergeant-at-Arms, please close the Bible.

*(Governor returns to his station, other officers and members remain in defending circle.)*

GOVERNOR: Brothers, has any matter of importance been overlooked or neglected?..... Our business being concluded; let us go forth with good thoughts, good words and good deeds for all mankind. Brothers, I fraternally bid you "Good Night" *(Good morning, good afternoon, good day.)*

*(Following the closing ceremony, the Sergeant-at-Arms will collect the Bible, Altar and station cloths, officers' emblems, flag, chimes and rituals and put them away for safekeeping.)*

## ENROLLMENT CEREMONY

### INSTRUCTIONS TO GOVERNOR FOR CLASS ENROLLMENT

*When an enrollment is held at a regular or special meeting, and family members have not been invited to view the enrollment or to hear the speaker, the Lodge must be opened and closed according to the Ritual. A motion may be accepted to dispense with the regular order of business of the Lodge. The Governor will refer to page 16 and conduct the meeting as outlined in those instructions.*

*When a special meeting has been called just for the purpose of enrolling candidates, and qualified family members have been invited to view the enrollment, the Governor will refer to page 16 and conduct the meeting as instructed.*

*(Before the meeting is called to order the stations and Altar should be as for a regular meeting, and draped, with the addition of Orator's chair, diagram 1.)*

*(Officers should invest themselves with their emblems and all officer stations should be filled with pro-tempore officers, if possible.)*

*(If possible, a microphone should be in position at the Governor's station and in position 8. A suspended microphone is preferred in position 8. All ritualists are instructed to use microphones if available for a class enrollment.)*

*(The Administrator should certify that all candidates are fully qualified to be seated in the class.)*

*(Qualified family members should be invited into the hall and seated to the left of the Prelate's station (position 12). Announce in the social quarter's, at least 10 minutes before the meeting, that beverages will not be permitted in the meeting room. Normal social quarter operations may be allowed to continue, if they do not interfere with the Enrollment Ceremony.)*

**SPECIAL INSTRUCTIONS**

**CHANGES PROHIBITED.** All ritual parts must be delivered from memory. No alterations, additions, or omissions will be permitted. Only Lodge members in good standing, candidates for enrollment, guest speaker, and qualified family members may be present during the ceremony. When an enrollment ceremony is scheduled, all other Orders of Business may be eliminated.

**GOVERNOR:** The Governor of the Ritual Staff shall have absolute charge and control during the enrollment ceremony ritual. He shall thoroughly familiarize himself with the ritual. He cannot read it too often or devote too much study to its proper exemplification. The enrollment ceremony gives the candidates their first impression of the Order and your lodge. Make those impressions proper and lasting, and it will reward your lodge with a lifelong member.

**RITUAL STAFF:** The Lodge Governor should appoint a Ritual Staff to confer the enrollment ceremony. Whenever possible, more than one Brother should be prepared to confer a part from memory. If a Lodge does not have a Ritual Staff, Lodge Officers must fulfill this responsibility. The Ritual Staff should rehearse with sufficient frequency to become letter perfect.

**OFFICERS PRO-TEMPORE:** It is the Lodge Governor's responsibility to see that the Officers' stations are filled during the opening and closing portions of the meeting.

**ADMINISTRATOR:** Prior to the enrollment ceremony, the Administrator must have on file a completed Official Membership Application, and have collected all required fees and dues from each candidate.

**ELECTRICIAN:** The Lodge Sergeant-at-Arms shall have charge of the lights during the enrollment ceremony. The Nine O'clock Ceremony picture and the Star Transparency are to be lighted during the entire enrollment ceremony.

**CONDUCT:** Everyone in attendance shall maintain silence and order, and refrain from smoking or consuming beverages during the meeting.

**APPAREL:** The apparel of the Ritual Staff shall be as follows: any appropriate, dignified and uniform mode of dress.

**CLASS:** Before the opening of the meeting, the Class shall be taken into the Lodge room and be seated as a body behind the Altar. Four (4) feet from and centered on the Altar (Position 11).

If only one candidate is to be enrolled, all provisions for and reference to the "Class" shall be omitted, and appropriate changes from the plural to singular shall be made in reference to the candidate.

If the wives, families and special guests are invited to hear the speaker, they should be ushered into the room and seated in their proper area. Lodge officers, dignitaries and others should always be introduced before the speaker.

If qualified family members have been invited to attend the class enrollment they should be ushered into the room and seated in area 12 before the Governor calls meeting to order.

## **INSTRUCTIONS FOR SPECIAL MEETINGS**

### **-OPENING-**

#### ***(WITH FAMILY MEMBERS PRESENT)***

**- Enrollment Ceremony**

**- Installation of Officers**

**- Mooseheart Founder's Day Ceremony**

**GOVERNOR:** *(Gives one rap)* Everyone will please be seated. I welcome you to our enrollment ceremony.

**GOVERNOR:** This meeting is called for the purpose of enrolling candidates *(or other ceremony listed above)*, and no other business will come before the Lodge.

**GOVERNOR:** *(two raps)* The Prelate will open the Bible and deliver the opening prayer.

*(The Prelate goes to position 1 faces the Altar, and in a dignified manner opens the Bible.)*

PRELATE: This is the Holy Bible; our inspiration and our guide.

*(Prelate steps back one step into position 1 area)*

PRELATE: Let us fold our arms and bow our heads.

*(Prelate slowly raises his head and delivers his prayer.)*

PRELATE: Supreme Being, Creator of the universe and Father of all mankind, we give You thanks for our fraternal brotherhood and the great precepts it embodies. Keep us diligent and mindful of our commitments to You, our children, our senior members, our families, and our communities. Give us a spirit of peace, harmony, and progress as we carry on these precepts in our Lodge, and in our lives. Remind us each day that the greatest good we can do is to serve You through service to our fellow man. Amen

MEMBERS: Amen.

*(Prelate returns to station.)*

GOVERNOR: *(U.S. Lodges)* I present the flag of our country *(turns to face Flag)*. Place your right hand over your heart and join with me in the Pledge of Allegiance.

### **PLEDGE OF ALLEGIANCE**

"I pledge allegiance to the flag of the United States of America, and to the Republic for which it stands, one nation under God, indivisible, with liberty and justice for all."

CANADIAN GOVERNOR: I present the flag of our country *(turns to flag)*. Brothers, salute the flag. You will join me in singing "O Canada."

GOVERNOR: *(Gives one rap)* Everyone will be seated.

### **OFFICIAL VISIT**

*(This ceremony is to be used whenever a Supreme Lodge Officer or Representative officially visits a Lodge.)*

GOVERNOR: At this time we are privileged to have \_\_\_\_\_ (name) \_\_\_\_\_ (title) visiting with us. \_\_\_\_\_ (first name) welcome to \_\_\_\_\_ Lodge \_\_\_\_\_.

**ENROLLMENT CEREMONY**  
**HELD IN CONJUNCTION WITH LODGE MEETING**  
*(#11 in Order of Business)*

GOVERNOR: *(Gives one rap with the gavel)* Brother Administrator, have the candidates seated before me met all the requirements for membership in our Order?

*(If any requirement has not been met, it must be addressed before the Ceremony begins.)*

ADMINISTRATOR: Brother Governor, they have.

GOVERNOR: We want to welcome you! Before we start the Enrollment Ceremony, I would like to give you a few instructions.

The gavel is the sign of the Governor's authority. One rap calls the Lodge to order or seats members when standing. two raps, call up the Lodge.

During the enrollment I ask you to please refrain from smoking, and unless otherwise instructed, remain seated, and please turn off pagers and cellular phones.

You will now learn more about the Moose Fraternity by hearing "The Story of the Moose". The Ritual Staff will now take their assigned positions.

RITUAL GOVERNOR. *(Standing) (After staff has taken their chairs the Governor raps once.)* We are certainly glad that you have taken this step to join our Fraternity. As you do so, you will leave your footprints in many ways, and in many lives. This includes the members of your family...the members of your new Lodge...and many persons you may never even meet. Since you have met all the requirements for membership in our Order, I would like to invite you to join us in one of our fraternity's most solemn moments: the Enrollment Ceremony of the Loyal Order of Moose. The staff telling the story of the Moose is from \_\_\_\_\_ Lodge \_\_\_\_\_. Listen carefully to the message each

member will bring to you.

You will now be given the opportunity to learn - and if you are so willing - to embrace the noble principles upon which this proud family fraternity is built. I ask you to ponder them in both mind and heart, for if you choose to join with us, these principles will bind us together forever, in a life of service to others.

Listen as the Sergeant-at-Arms helps you to begin your journey.

*(Sergeant-at-Arms rises as Governor is being seated and advances to position 8.)*

**SERGEANT-AT-ARMS:** When you receive your Moose membership card it will be only inches high, but miles wide. I say this because it opens up a whole new world of privileges for you and your family.

First, there are the many privileges you will have in your Lodge. Time after time, week after week, you can participate in recreational events tailored to your personal tastes, and those of your family, or other qualified guests. Expect this feeling of fun and fellowship to be a life-changing experience.

Secondly, there are the privileges that extend beyond your Lodge. These include special opportunities to participate in local, regional, and national programs that not only help others, but will allow your family to grow closer together as well.

Another privilege of membership, is to be able to attend Lodge meetings and vote in matters brought before the Lodge. You will also be able to invite your associates into this great fraternity.

When we talk membership, we're also talking about the Women of the Moose. For many successful years, membership in the Moose has meant a special opportunity for the women in your family to also participate in this dynam-

ic International Order.

Carry and show your membership card proudly, as it is one of the most valuable cards in your possession, one that continues to pay you dividends year after year.

Our Orator will now explain some of these dividends to you.

*(Sergeant-at-Arms returns to his chair, turns left and is seated. Orator rises and advances to position 8 as Sergeant-at-Arms returns to chair.)*

ORATOR: When you are thinking about your Moose membership, think of all the sports and family activities the Moose has available. What's your choice, cards... golf... bowling... pool... darts... teen nights... picnics... or simply cheering your team from the stands? They're all waiting for you. So are such pleasures as the Friday or Saturday night dinners, the annual holiday festivals, plus all the special family events in between.

The M in "Moose" stands for "more." More sporting and family opportunities in which to participate, and to share your interests with others. To put that another way: wherever you find fun, you'll find the Moose. Fun that warms the heart and links our lives.

What is essential to remember is that this family fraternity is and always has been a private organization whose privileges belong only to its members. Private organizations can retain their protected and tax-free status only so long as their members adhere to this requirement. Family and other qualified guests are welcome, but only when accompanied by the member and his membership card.

As you reach out and take the oath, you reach out to an entire network of fun, friendship, and obligation. You and your family will soon be saying, "This is the best decision we ever made."

Our Prelate will now tell you more of our involvement in

other areas.

*(Orator returns to his chair and is seated. Prelate rises and advances to position 8 as Orator returns to chair.)*

PRELATE: There are two sides to the Moose story: the receiving and the giving. While the "receiving" is good, the "giving" is even better.

Throughout its long honored history, the Moose Fraternity has always focused on giving something back. It is altogether proper that you should know that service is an important part of this story. That means members giving of their time and effort to make their communities better places in which to live.

Is it a neighborhood in need... a family in crisis... a threat to health... or an educational opportunity for those without means? Wherever and whenever the need, the Moose is there to enrich the "circle of life."

As you step forward, you step into a noble family fraternity where "commitment and service" stand on a par with "fun and fellowship". This is what helps make the Moose so unique, and the path your footprints take so important.

While we support our communities, we aren't forgetting our children. Listen while the Junior Governor shares one of our finest achievements with you.

*(Prelate returns to his chair and is seated. Jr. Governor rises and advances to position 8 as Prelate returns to his station.)*

JUNIOR GOVERNOR: There is nothing in the world as sweet as youth, and nothing in our fraternity as caring as the child city we call Mooseheart. Dedicated to providing a home for children in need, Mooseheart is located 40 miles west of Chicago. This self-contained "child city" has stood like a beacon of hope since its founding in 1913. It is a model community populated with loving teachers and mentors, who stand strong along every step of a developing

child's pathway.

Mooseheart. Call it love... call it security... call it a heart-warming chance to turn tragedies into triumphs. Whatever you call it, Mooseheart is one of the most enduring contributions this fraternity makes to society. And now we ask you to help us keep our dream alive, the dream that says every child without a family deserves to have one. Since opening its doors, thousands of children have called Mooseheart home.

The operating cost for our 1000 acre campus, the facilities, the staff, and its many programs has partially been met by our annual membership fees. Members also have an opportunity to give to the Mooseheart/Moosehaven Endowment Fund, and give they have, with love and generosity. Later, when you are asked to take the oath, you too will have this chance to help nourish our dream, and provide the dollars to make that dream come true. It is where your mark will be felt in the lives of the young.

Our Nine O'clock Ceremony gives us an opportunity to reflect more deeply upon the value of Mooseheart. The Governor will now lead us in the Nine O'clock Ceremony.

*(Jr. Governor returns to his station and remains standing. Governor rises as Jr. Governor leaves position 8.)*

GOVERNOR: *(Gives two raps as Jr. Governor turns at chair.)* Everyone will please rise. It is now nine o'clock. At this time the little children at Mooseheart kneel at their beds to say their evening prayers. Let us face toward Mooseheart, fold our arms, bow our heads and join them in silent prayer.

*(The lights are turned low and chimes sound slowly nine times. After the ninth stroke the Governor continues.)*

Repeat after me: Let the little children come to me...(repeat) do not keep them away...(repeat) for they are like the kingdom of Heaven...(repeat) God bless

Mooseheart...(repeat) Amen. (repeat)

GOVERNOR: Everyone will please face the Altar. (*Lights are turned up and Governor gives one rap*) Please be seated.

There is another inspired venture of our fraternity, and the Past Governor will now share part of that story with you.

(*Past Governor rises and advances to position 8 as Governor is being seated.*)

PAST GOVERNOR: If youth is to be cherished, then age is to be honored. Located in the warm Florida sunshine, Moosehaven is a complete community for our senior members - both men and women. Moosehaven opened its doors in 1922 to a special world of comfort and convenience, designed especially for those members who seek a sanctuary from the cares and burdens age sometimes imposes on those young of mind, but in need of a helping hand.

Moosehaven - set in a paradise environment just outside of Jacksonville, Florida - illustrates that this fraternity not only cherishes its young, but honors its seniors. As you enter our fraternity's ranks, you not only are helping to keep Moosehaven's lights burning brightly, but you are warming our residents hearts as well.

Through your membership, if you or your family ever have a future need, you are now able to request the benefits and blessings of both Mooseheart and Moosehaven. These extra benefits of membership are some of the most important dividends you will enjoy in this Fraternity. Always keep your dues current, so you and your family are never without this valuable protection.

As you can see, the Loyal Order of Moose puts a priority on caring. The contributions made by all of us to the Mooseheart/Moosehaven Endowment Fund, enable us to provide our Moosehaven residents with the life they so richly deserve. What nobler commitment can there be?

And now, with some added thoughts, here again is the

Governor.

*(Past Governor returns to station and is seated. Governor rises and advances to position 8 as Past Governor returns to station.)*

GOVERNOR: Earlier, we spoke of the privileges of membership and the Private Policy. These regulations are a small price to pay for the legal protections we have always enjoyed. In stepping forward today, you are asked to faithfully abide by this principle, and display your membership card when entering a Moose Lodge.

Now I ask if each of you believe in the purposes of the Order we have been describing, and if you sincerely desire to join with us as Brothers? If so, please answer "I do."

Give your full attention to the obligation you are about to receive. Once taken, it shall bind you to us, and us to you, for all time:

In the presence of the Supreme Being and those gathered here, I pledge that I will obey the laws of the Loyal Order of Moose, and the By-laws of the Lodge of which I am to become a member.

I will propose for membership in this Order only those of high personal character, and never oppose a qualified applicant without just cause.

I will bring my concerns to the leadership of this Order, as provided by our laws, before appealing to any Civil Authority.

I will cherish and support with my energy and substance, our youngsters at Mooseheart, and our seniors at Moosehaven.

Always remember, there is strength in unity, for a burden heavy to one is borne lightly by many.

All candidates, and Lodge Brothers desiring to reaffirm their faith in our Fraternity, will please rise. *(pause)* Place your left hand over your heart, raise your right hand and

repeat after me, using your name where I use mine.

I \_\_\_\_\_ - freely and without reservation - accept the honor - and obligation of membership - in the Loyal Order of Moose. - I pledge my service to my Brothers, - and to all members of this Order - this obligation - will bind me for all time.

You may lower your hands. By virtue of the authority given to me by this Lodge, I now declare each of you a member of the Moose Fraternity. Welcome, Brothers! On behalf of this Lodge, we are honored that you have joined with us in this most noble Order. Everyone will please rise. The Prelate will now lead us in prayer.

*(Governor moves to position 2 and faces Altar. Prelate rises and advance to position 1 area as Governor moves to position 2.)*

PRELATE: Let us fold our arms and bow our heads. Almighty Father, who knows the hearts and minds of all His people, help each of us to accept - and continue - the oath of Moose allegiance. We ask You to hold us together in Your arms as we commit our lives to fraternity, fellowship, and service. We also ask You to bless Mooseheart and Moosehaven, so they will always be there for those in need. Amen.*(Staff repeats "Amen")*

*(Prelate returns to his station and remains standing.)*

GOVERNOR: Everyone please be seated. *(Pause until everyone is seated)* Congratulations. With this ceremony, we have become as one. One in spirit... one in purpose... and one in commitment.

As new members of our Order, you are charged with two essential obligations. The first is to protect those within our Order. This includes your fellow members, your families, and your fraternity itself, which includes the work of Mooseheart and Moosehaven. Secondly, there is the obligation to strengthen our membership. This calls for your best

efforts to encourage those qualified friends, relatives, and associates to join with us. By sponsoring them into our Order, you will not only help us grow, but you will be sharing all the benefits and privileges of this Order with others.

We wish to thank you for your participation, and your attention. This ceremony will conclude as the Ritual Staff vacates their positions.

*(Lodge Officers will again take their stations.)*

GOVERNOR: *(Thank the Ritual Staff for their performance and have Ritual Governor introduce Staff).*

GOVERNOR: It is my privilege to acquaint the members of this Lodge with the Moose Legion and the Higher Degrees of our Order.

Every Moose member that meets the minimum requirements is eligible to make application for membership in the Moose Legion, the Degree of Service. The purpose of the Moose Legion is to band together those loyal and devoted members of the Moose who desire to make further contributions to the humanitarian objectives of our Order, plus forming a strong foundation for advancement to the higher degrees.

The Fellowship Degree of Honor, is conferred only upon Moose Legion members who are specifically called to receive this Degree. This honorary Degree comes as a reward for outstanding service rendered to the Order, and is a much coveted mark of distinction.

The ultimate and highest Degree bestowed on a member of the Moose is the Pilgrim Degree of Merit. This Degree is conferred only in the House of God at Mooseheart, and comes as a reward to members of the Fellowship Degree for exceptional and outstanding service to the Order.

It is sincerely hoped that every member of this Lodge will devote himself toward the magnitude of Moose service that merits these higher Degrees.

*(During Lodge meeting proceed with regular Order of*

*Business on page 12.)*

**INSTRUCTIONS FOR SPECIAL MEETINGS**

**-CLOSING-**

***(WITH FAMILY MEMBER'S PRESENT)***

- Enrollment Ceremony**
- Installation of Officers**
- Mooseheart Founder's Day Ceremony**

GOVERNOR: *(Introduce Officers and dignitaries or other visitors.)*

GOVERNOR: *(Introduce Sr. Regent and request she introduce other W.O.T.M. officers present.) (No Speeches).*

GOVERNOR: *(Recognize Official Visitor for his/her comments.)*

GOVERNOR: *(Call on Administrator for final instructions to new Brothers.) (Depending on size of class, lapel pins may be presented to new members by sponsors or officers if sponsors are not present. If class size is too large, lapel pins should be presented after adjournment.)*

GOVERNOR: *(Make final remarks.)*

GOVERNOR: Brother Sergeant-at-Arms; Please close the Bible and place the Endowment Fund Cradle upon the altar.

GOVERNOR: *(Gives 2 raps)* Everyone will please rise. The Endowment Fund is vital to the daily operation of both Mooseheart and Moosehaven. Anyone desiring to contribute to this fund is asked to approach the altar in an orderly manner, make your contribution, then return to your place and remain standing.

*(After all have returned to their places, the Lodge Governor delivers his final charge from his station.)*

GOVERNOR: *(From station)* Our business being concluded; let us go forth with good thoughts, good words and good deeds for all mankind. I fraternally bid you "Good night."

(or "Good Afternoon," or "Good Morning.")

### LINE OF MARCH FOR RITUAL CLOSING

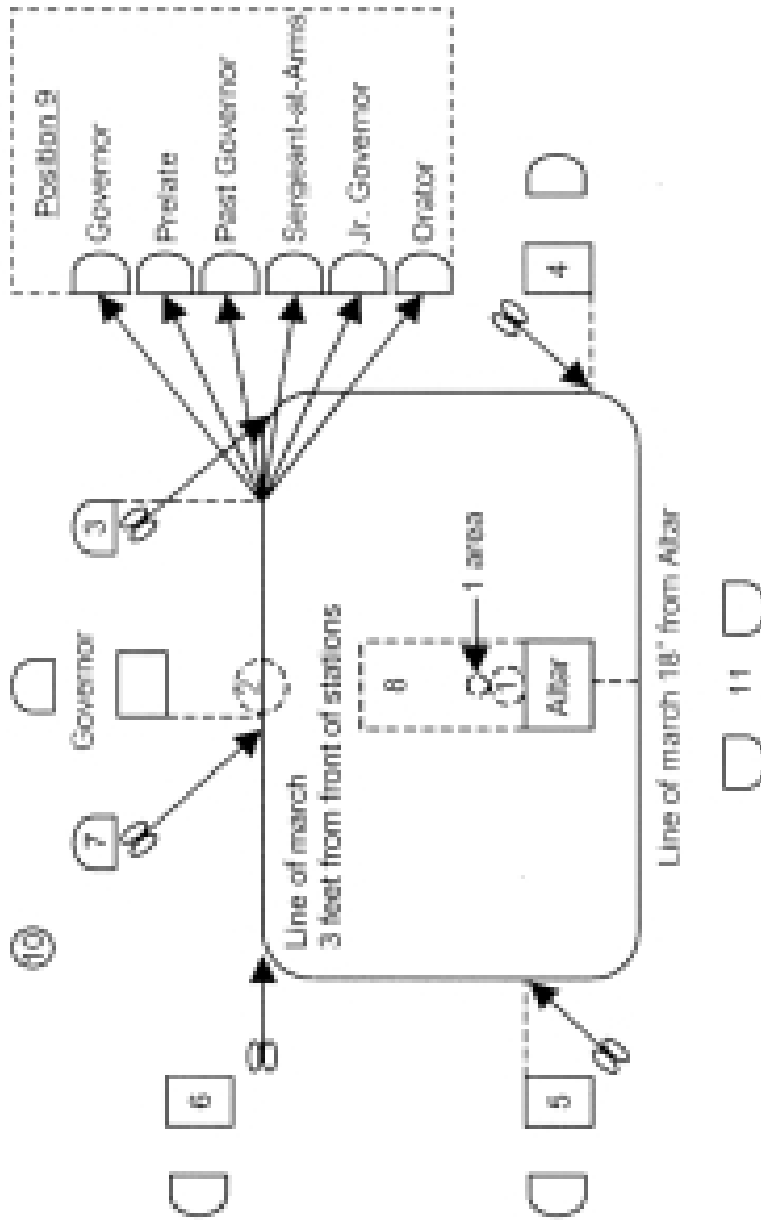

---

## DIAGRAM NO. 2 FLOOR POSITIONS

5 These instructions cover work on a standard size floor requiring spacing of 12 feet from front of Prelate, Jr. Governor and Governor's station to center of Altar. When this spacing is not possible, allow 12 feet from front of Governor's station to center of Altar and adjust remaining distances as necessary. Sufficient spacing shall be allowed for the Class behind Altar. (*See diagram 1, on page 3.*)

10 Diagrams 1 and 2 illustrate many floor positions designated by number as follows:

Position 1. Prelate's position for opening the Bible is in center of Altar and with toes within one foot of the Altar.

15 Position 1 Area. 12 to 18 inches from Altar centered for Prelate's prayer.

Position 2. Centered and 3 feet in front of Governor's station on line of march.

20 Position 3. Orator's chair is 3 feet to the left of the Governor's station, with front edge of chair in line with the back edge of Governor's station.

Position 4. Prelate's station.

Position 5. Jr. Governor's station.

25 Position 6. Past Governor's station in line with front of Jr. Governor's station, and left side of his station in line with front edge of Governor's station.

Position 7. Sergeant-at-Arms chair is 3 feet to the right of the Governor's station, with front edge of chair in line with the back edge of Governor's station.

30 Position 8. An area located between the Altar and Governor's station, with the back edge 5 feet from the Altar. Area is as wide as a standard Altar (32 inches). Toes should be within these limits at all times while addressing class.

Position 9. Chairs for Ritual Staff on exit.

Position 10. (*For Competition*) Your Country's flag is 7 feet to the right of the Governor's chair and in line with it.

Position 11. Two chairs for Class during competition. Front edge of both Chairs are 4 feet from Altar and 3 feet apart, equally centered on Altar. 5

Position 12. (*Not for competition*) Chairs for Qualified Family Members (*see Diagram No. 1*).

Position 13. (*Not for competition*) Optional State, Provincial or National Flag. 10

The symbolic direction for Mooseheart in competition is centered behind the Prelate's station. A Nine O'clock Ceremony picture should be placed in this area. The symbolic direction for Moosehaven in competition is centered behind the Jr. Governor's station. 15

## FLOOR MOVEMENTS

The Ritual Governor will rap the gavel once while standing at his station to start Enrollment Ceremony or Ritual Competition, after staff has taken their chairs.

Staff members should avoid looking at the floor at any time. 20

Each staff member should enter and leave his station with the station on his left. He should not put his hand upon his station. Touching the Altar Cloth, or brushing against the Altar or Stations is not a violation, however kicking chair, stations, or Altar, or dropping of mallet or gavel is not permitted. He should not move his chair or put his hand on it when rising or being seated, unless permission to do so has been granted by the judges. It is not a violation if the class should move their chairs. 25

When a staff member rises from his chair for the purpose of moving to a floor position, he may pause before stepping off, but once started he should continue without interruption 30

until he has reached his position.

All movements should be graceful. A ritualist may move within the parameters of Position 8, but toes must remain within its boundaries.

5 Facing the Bible, flag, Moosehaven or Mooseheart should be done by centering the body in that direction. Centering the body means turning both feet in that direction. This also applies to Governor when speaking from his station or position 2.

10 Leaving position 8 is defined as the time after pivot on turn when a foot crosses the outer edge of position 8 to the time the trailing foot is out of position 8.

15 Staff members should turn left and step off on left foot to go left, and should turn right and step off on right foot to go right. The turn is made by a slight pivot on the ball of the opposite foot, then stepping off with required foot. Do not turn both feet simultaneously. Stepping off means raising the foot and moving it in the direction of intended move.

20 When the Governor, Prelate and Orator leave Position 8, they should turn to their left and step off on their left foot and go to their positions. The Jr. Governor, Past Governor and Sergeant-at-Arms should turn to their right and step off on their right foot and go to their positions.

25 All staff members should go to and from floor positions by the shortest possible route except on vacating, or where movements are prescribed. The shortest route is a straight line between the positions and then turning in place without moving forward, backward or sideways. A side step may be made when leaving chair at station.

30 There should be no unnecessary delay in following Governor's instructions.

Heads may be turned at any time for the purpose of watching the movements of others, or to put attention on the Governor.

The Governor is responsible for establishing the correct line of march on exit and each staff member should straddle the correct line of march at all times.

## GESTURES

A gesture is an expressive movement of the body, or part of the body, used to emphasize an idea, emotion, action or specific point. 5

Timely hand gestures that are smooth and graceful should be used during every charge.

A gesture is most effective when it is made at the same time as the words related thereto are spoken. The Governor may be instructed otherwise. 10

Nodding or shaking the head may be used to emphasize meaning, but constant movement of the head is prohibited.

Each staff member should use relaxed open-handed gestures, but may use finger or fingers, or relaxed closed hand motion to emphasize a point. When not gesturing, his hands should be in front of his body or at his sides. He may clasp his hands or fingers together, but should not hold them behind him, put them in his pockets, or place them on his hips. 15

Unless otherwise instructed, and when gesturing after taking his attention off the class, he should use left hand when gesturing to the left, and right hand when gesturing to the right. When gesturing in the direction of the Altar or Class, he may use either or both hands. 20

When the attention of the speaker is not on the class, because he is using a gesture and speaking in that direction, he should position his body in that direction. Positioning the body requires the turning of both feet. He may vary from required floor position to make gesture, but must return to required position after gesture. 25

When gestures are made only to help express oneself, and 30

attention is still on the class, the hand or hands may be extended to the side and away from the body. Constant use or movement of the hands is permitted, and either or both hands may be used for these gestures. A staff member  
 5 should speak in the direction of a gesture when his attention is not on the class. Looking at the hands when gesturing is not a violation if facing the class.

He should not rock on his feet, continually bob or shake his head, or permit his hands to indicate nervousness. In fact,  
 10 he should do nothing with his hands, head or body that will distract from his talk.

Gestures should be used in motioning the class or staff to rise or be seated. Gestures are permissible at the Governor's station and position 2. A left hand gesture toward the direc-  
 15 tion of Mooseheart is required for the Nine O'clock Ceremony.

Governor does not gesture returning from Nine O'clock Ceremony.

Hand gestures should not be made during the repeated por-  
 20 tion of the Obligation.

### **ATTENTION AND SPEAKING**

Each staff member should start and complete his charge in Position 8 by facing the class. He must stop and establish position before speaking or moving.

25 While in Position 8, staff members should speak only to class or in the direction of a gesture. When taking attention off the class, you must speak in the direction of the gesture as eye contact has been made with the object that you are gesturing toward. When returning his attention to the class,  
 30 he should turn as he looks at and speaks to the class. He should speak on his turn, and his attention must be directed to the class.

Staff members need not complete a sentence before shifting

attention. Unless speaking in the direction of a gesture, body position and attention of the speaker (except the Governor when otherwise instructed) should always be directed to where he is speaking.

A nod of the head SHOULD NOT be given upon the completion of a charge. 5

Avoid dropping the voice at the end of a sentence. Enunciate clearly, pronounce words correctly, and speak LOUDLY and SLOWLY enough to be understood.

The Ritual Staff should be attentive at all times and should have their attention on the person speaking. Staff should be uniform in positioning their hands while seated and should do nothing to cause distraction while at chair or station. 10

Staff members should be friendly and relaxed in delivering their parts. They should refrain from a monotone or singsong delivery, and should give their charge with impressiveness. The Ritual is not intended to be humorous, therefore there is no place for a continuous grin, but an occasional friendly smile will add to your impressiveness. The speaking parts must be given in full, exactly as written. 15

## INDIVIDUAL INSTRUCTIONS 20

The enrollment ceremony and judging for competition begins when the Governor raps the gavel at his station, and will end when staff is seated uniformly in Position 9.

The Governor will give his initial charge from his station. 25

Sergeant-at-Arms rises as Governor is being seated and steps off on left foot and advances to position 8. The Sergeant-at-Arms should raise his right hand to make voting sign gesture starting on either of the words "and vote." When he completes his charge, he should turn right, step off on right foot, go to position 7, turn left and be seated. 30

The Orator should remain seated until the Sergeant-at-Arms

has completed his charge. As the Sergeant-at-Arms leaves position 8, he should rise and step off on right foot. He should not start charge until SAA is seated. When completed, turn left, step off with left foot, and go to position 3, turn right and be seated.

5 The Prelate should rise and move from his station as the Orator leaves position 8. He should not start his charge until the Orator is seated. When completed, turn left, step off with left foot and return to his station and be seated.

10 The Junior Governor should rise and move from his station as the Prelate leaves position 8. He should not start his charge until the Prelate is seated.

15 Upon completion of the Jr. Governor's charge, he should turn right, step off on his right foot, return to his station and remain standing. The Governor rises as Jr. Governor leaves position 8. As the Jr. Governor is turning at his chair, the Governor should rap twice to raise everyone for the Nine O'clock Ceremony.

20 In competition, for the Nine O'clock Ceremony, the Ritual Governor, after rapping the gavel, should instruct everyone to rise or be seated. The staff should rise immediately after the second rap of the gavel and be seated immediately after the single rap. The Governor should face the class for rap of the gavel before the Nine O'clock Ceremony charge.

25 The Nine O'clock Ceremony picture should be used as the direction of Mooseheart. The Governor should gesture, then turn toward the picture after saying "Mooseheart". The staff should turn in unison with the Governor, and in the most direct way to face Mooseheart. Prelate turns left to face Mooseheart and turns right to return. Governor shall not proceed until all members of class are facing in direction of Mooseheart.

30 Staff members should fold their arms and bow their heads in unison for the prayer and Nine O'clock Ceremony, and folded arms should be uniform.

The staff member sounding chimes should follow instructions for turning and assuming prayer posture. He should then break prayer posture by dropping both arms, raising head, sound chimes slowly and only the required 9 times using same note or tone, after which he should resume prayer posture by folding arms then bowing head. The Governor should pause a moment after last chime to give member time to resume prayer posture. The Governor should raise his head to normal speaking position to deliver the Nine O'clock Ceremony. After repeating "Amen", staff should break prayer posture in unison and return to former positions in unison after instructions by the Governor. 5 10

After the class and staff has returned to their former positions, the Governor should rap gavel, then tell everyone to be seated. Staff seats on rap of gavel, but Governor does not seat himself. 15

A Ritual Staff is expected to know when they are to rise, be seated, or move and they should do so even if not so instructed by the Governor, or movements of other staff members. 20

Past Governor rises and moves to position 8 as Governor is being seated.

When Past Governor completes his charge, he turns right, steps off on right foot, returns to station and is seated. After completion of the Past Governor's charge, Governor rises and moves to position 8 as Past Governor leaves position 8, not speaking until the Past Governor is seated. 25

The Governor should demonstrate his instructions by using a gesture for rising, placing his left hand over his heart and by raising his right hand. The staff should rise and repeat the obligation with the candidates. Governor should lower his hands without gesturing, after he instructs class to lower theirs. 30

Staff will rise in unison immediately after Governor says

"please rise". Staff will place left hand over heart, and raise right hand in unison and uniformly with the Governor. Staff will repeat obligation with the candidates. Staff will lower hands in unison with Governor.

- 5 The Governor should be speaking to the class when he says, "Everyone will please rise." The Prelate should move to position 1 area as the Governor leaves position 8. The Governor turns left to move to position 2, turns left in position 2 and remains standing. Prelate does not begin prayer  
10 until Governor is in position 2.

The Prelate should advance to position 1 area, face the class and assume prayer posture, he should slowly raise his head to normal speaking position and deliver his prayer. Staff should be in unison in raising arms and bowing heads, and  
15 arms should be folded uniformly.

At the completion of his prayer, the Prelate should hold his position until staff has repeated "Amen". The staff and the Prelate should break prayer posture in unison. The Prelate should turn left, step off on left foot and return to his station  
20 and remains standing.

The Governor delivers his final charge from position 2 after the Prelate returns to his station. He must use gesture after he instructs everyone to be seated. Staff should be seated without hesitation and in unison.

- 25 The staff will rise in unison. The Prelate and Jr. Governor step to the right front corner of their stations and stand at a left oblique. The Past Governor steps to the right front corner of his station and will face forward. The Prelate, Jr. Governor and Past Governor should be the same distance  
30 from the corner with their heels clearing the front edge of their station, referring to Diagram 2 on page 28. The Orator and Sergeant-at-Arms remain standing centered in front of their chairs, but both turn on a left oblique in preparation to enter the line of march as shown in the diagram on page 28.

35 On vacating, the Governor (in Pos. 2) turns left astride the

line of march after staff rises. The Governor should pause to allow the staff members time to complete their unison moves before leading off. He then steps off on his left foot, and proceeds per diagram on page 28. The Orator follows the Governor and should enter the line of march at the corner area as shown, followed by the Prelate, Jr. Governor, Past Governor and Sergeant-at-Arms as indicated by the same diagram. The line of march is a line 3 feet in front of stations, except when passing between the Altar and class, which is a line 18 inches from the Altar. Staff members should be in step with the Governor or the man in front of himself, and may step off on either foot. The Governor is responsible for establishing the correct line of march on exit, but each staff member should straddle the correct line of march. Equal spacing of staff members should be maintained until point of veering at the Orator's chair is reached, to go to assigned chair in Pos. 9 (*as per Dia. 2, Page 28*). The Governor, Prelate, and Past Governor veer to the left and turn left in front of their chairs, and Orator, Jr. Governor and Sergeant-at-Arms veer right and turn right in front of their chairs. Heads should be looking forward after making turn in front of chair. Staff members should be seated simultaneously and in a uniform manner as soon as Sergeant-at-Arms turns at his chair. Placement of the hands should be timely and uniform. To show the importance of the ceremony, this dignified manner should be maintained for a few seconds during a competition or until otherwise specified at a meeting.

If any Ritual Staff members are Officers of the Lodge, they may again take their proper places without further formality.

## **RULES OF RITUAL COMPETITION**

All Association Ritual Competitions will be under the jurisdiction of the Regional Manager. It shall be his duty to appoint a Chairman of the Competition Committee, as

well as to select a time and place for the competition. If necessary, he will also appoint a Judging Committee Chairman. The out-of-state judges are not permitted to serve as Chairman of the Competition Committee, or as  
5 Chairman of the Judging Committee. Competition Chairmen may not compete in the Ritual Competition.

Each State or Provincial competition will qualify at least 2 staffs for International Competition. In addition, 1 more staff will qualify for each additional 5 staffs (*or parts there-*  
10 *of*) when over 10 staffs are entered in competition. Non-qualifying staffs, in order of finish, may substitute for qualifying staffs not wishing to compete in International Competition.

If an Association(s) chooses to not send a staff(s) to the  
15 International Competition, those time slots may be awarded to another Association(s). This will be done only if the State or Provincial competition has more than 15 staffs competing or greater than 25% participation from the total number of lodges in that Association. It is at the discretion  
20 of the Moose International Director of Ritual to determine how many time slots will be awarded to those who qualify.

Only Lodges in good standing in their Associations are eligible to enter State, Provincial or International competitions.

25 A Ritual Staff shall consist of a Past Governor, Governor, Junior Governor, Prelate, Orator and Sergeant-at-Arms. Clothing should be uniform; any appropriate and dignified mode of dress is acceptable.

30 Medallions issued to the International Champions, or medallions issued by State or Provincial Associations, may be worn by the champions at class enrollments, but never in any competition.

For competitions, the Enrollment Ceremony shall be conferred upon two candidates (*Moose Members*), and the

Ritual Staffs are responsible for furnishing their own class members.

JUDGES: Moose International shall sanction all judges for International, State and Provincial ritual contests. A list of qualified judges is available. 5

JUDGING: Competing teams will be judged on ritualistic accuracy, delivery, general effects, candidate appeal, and individual floor work. A perfect team score is 600 points. *(100 points for each Ritualist.)* 10

RITUALISTIC ACCURACY: 50 points: For every word omitted, added, transposed, slurred, or substituted in the speaking parts of the Ritual, or for each indicated pause omitted or added in the obligation or the individual parts, 1/4 point will be deducted. 10

For each prompt given, 1/2 point will be deducted. A prompt will consist of whatever number of words are needed for the speaker to recover. A new prompt may be given later. Judgment should be used as to when a speaker has fully recovered, before being charged with another prompt. 15

Fill-in words such as nicknames will not be judged. 20

DELIVERY: 8 points: Speaking, 4 points *(1/4 point penalty; too fast, too soft, too soon, too late, monotone, singsong, pronunciation)*; Gestures, 4 points *(1/4 point penalty; not graceful, forbidden, wrong hand, not enough, missed, not timely, body position)*. 25

GENERAL EFFECT AND CANDIDATE APPEAL: 26 points: General appearance, 2 points *(1/4 point penalty; untidiness of clothes, person or grooming, shoes not shined, tie not straight, not uniform in dress)*; Attention to class, 4 points *(1/4 point penalty; not enough, too much, untimely)*; Impressiveness, 20 points *(left to discretion of the judges; Poor - 1 to 16, Fair - 16.0625 to 17, Average - 17.0625 to 18, Good - 18.0625 to 19, Excellent - 19.0625 to 20.)* Point 30

spread may be as small as 1/16 of a point, i.e. .0625, .1250, .1875, .2500, .3125, .3750, .4375, .5000, .5625, .6250, .6875, .7500, .8125, .8750, .9375, .0000.

5 Impresiveness scores reflect the speaker's ability to enunciate clearly, properly express himself, move about and use smooth, timely and proper gestures, project confidence in a relaxed and friendly manner, and speak loudly and slowly enough to be understood.

10 INDIVIDUAL FLOOR WORK: 16 points: Vacating 4 points, (*1/4 point penalty; looking at floor, not correct, too military, out of step, confused*). Entering and Leaving (*Stations*), 4 points (*1/4 point penalty; untimely, careless, incorrect, looking at floor, not uniform*); Floor Positions and  
15 Movement, 6 points, (*1/4 point penalty; incorrect, not uniform, looking at floor, inattentive, untimely, careless*); Conduct at Stations, 2 points (*1/4 point penalty; inattentive, tense, restless, not uniform*).

20 ENTRIES: Entries for competing staffs must be sent to the Chairman of the Contest Committee before the publicized deadline. Before competing, the captain or an authorized representative of the staff should report any substitutions to the Chairman of the Contest Committee. After entry, not more than three substitutions may be made.

25 All Ritualist, and Class members, must be officially registered at the convention before participating in International or Association Ritual Competitions.

30 In State or Provincial Competition, the Chairman of the Competition Committee, and the Chairman of the Judging Committee will be appointed by the Regional Manager subject to the sanction of Moose International. The State or  
35 Provincial Ritual Chairman may be appointed Chairman of the Judging Committee, but cannot then compete as a contestant. It will be the duty of the Chairman of the Competition Committee to arrange for an adequate room, properly set up and complete with the following: stations,

chairs, Altar, Bible, flag, gavel, Nine O'clock and Moosehaven pictures, Altar and station cloths, and chimes. When all paraphernalia has been placed for competition, only chimes, station chairs and chairs in Position 9 may be moved to satisfy each team, as long as third and fourth chairs still split the line of march. 5

The Chairman of the Judging Committee will assume full responsibility for conducting a proper competition and enforcing all rules pertaining thereto. He is given final authority concerning interpretation of the rules and will "NO CHARGE" any "hit" he feels is questionable. Judges may not make any changes once papers are given to the Chairman, except to make clarifications. Decisions of the Chairman of the Judging Committee will be final, and only tabulation errors and undisputed wrong posting errors will be corrected. Time limit for making corrections will be set by the Judging Committee Chairman. When tabulation errors or posting errors are reported within the time limit, but after trophies have been presented, a duplicate trophy should be awarded and it will be assumed there is a tie for the place in question. Cash awards should not be presented until scores have been adjusted and properly placed. When place of finishing has been announced, teams and individuals with an adjusted score will be placed in a tie with the team or individual scoring the same or next fewest points. 10  
15  
20  
25

Two Word Judges, and a minimum of two approved out-of-state Floor Judges will be used in all competitions which have six or more teams competing. When there are five or less teams competing, one approved out-of-state Ritual Floor Judge may be used WITH THE PERMISSION OF MOOSE INTERNATIONAL. Out-of-state Ritual Judges are not to accept responsibility as Acting Competition Chairmen, or as acting Judging Committee Chairmen. They are not permitted to attend a class enrollment just prior to competition to view a competing staff in action. Judge No. 1 is seated to the right of the Jr. Governor's station, between 30  
35

station and class. Judge No. 2 is seated between the Jr. Governor's chair and the Past Governor's chair. Judge No. 3, if used, is to the left of the Prelate. If only 1 judge is used, he shall judge from Judge No. 1 area. One Word  
5 Judge will do the word judging and the other will do the prompting. Word Judge and prompter are seated to the left of the Prelate.

Ritual Competitions are open to viewing by any good standing member of the Order including Ritual Team mem-  
10 bers entered in competition. Those in attendance shall to remain quiet and keep proper decorum. Spectators or competing ritualists are not permitted to move about, smoke, display or use papers or books, make any notes, or use any recording or electrical devices while a staff is competing.  
15 Cellular phones and pagers must be turned off.

A Ritual Team member who holds multiple memberships may compete with multiple teams in any competition providing he is qualified to be a member of each team he represents. A ritualist will only receive one award for his highest score. He may  
20 be used as a fill-in on any staff qualified to compete, but he must have already competed. A fill-in will not be scored. He may be used as the class prior to competing.

A ritualist who transfers his Lodge membership will be ineligible to compete in State, Provincial or International Lodge  
25 Ritual competitions for a period of six months, unless approved by Moose International.

The Judging Committee Chairman, Judges and Tabulator may not compete in any competition in which they are associated, nor may they be used as a fill-in or as a class.

30 The Lodge Secretary must certify on the Ritual Contest Entry Form (and under the Seal of the Lodge) that each member of the staff is in good standing in the Lodge, and that dual memberships, if any, have the required approval of the General Governor.

A team must report for competition 1/2 hour before their allotted time, unless an acceptable excuse is made to the Chairman of the Judging Committee by a representative of the team. The burden of proof for an acceptable excuse will be on the team. When the excuse has been found to be acceptable, the team will be rescheduled to the end of the competition, or as circumstances permit during the contest period. 5

In an emergency occurring just prior to or after arrival at place of competition, and for the purpose of permitting other members of the team to compete for individual awards, any member of the Moose may be used as a fill-in, and may recite or read the part. The fill-in will not be judged, nor will any score for him be given. The foregoing does not apply to a team using a qualified substitution. As many as three substitutions may be made after a Lodge has submitted their entry, however a full six member team may not split in half (3/3) to add an additional team to the competition count. 10 15

There may be a circumstance when a staff member is unable to continue, even after the staff has reported and entered into competition. Should this happen, activity will cease, and the team may be rescheduled to the end of competition - or as circumstances permit during contest period. Score sheets will be marked at the time of interruption. Although a member may commence again from the start of his part if he so desires, the judging will continue from the point of interruption. If necessary a substitution may be made, but will not be judged. Any member of the staff, or any member of the Judging Committee, may call for an interruption if, in his opinion, some member of the staff appears to be ill. 20 25 30

Judges are not permitted to leave their stations, or make any other distracting moves while a staff is on the floor. They should not converse with one another until papers are completed and given to the Chairman. Word Judges may ask 35

assistance from Prompter after staff is off the floor, but this should not be done in the hearing of others.

5 A competing Ritual Team must exit the floor after competition without conversing with Floor or Word Judges. A 1/4 point penalty may be assessed on the ritualist in violation.

10 Judges should not converse with a Ritualist concerning errors, or make any suggestions to him, until the entire competition has been completed and the score sheets have been distributed. The Competition Chairman may, however, answer questions prior to the Ritualist's appearance on the floor.

## SERVICE OF TRIBUTE

1. A permanent copy in a three-ring notebook should be kept by the lodge for use at all Service of Tributes.
2. Those selected to perform the ceremony should familiarize themselves with their parts, committing them to memory if possible.
3. Official Higher Degree Regalia may be worn and is encouraged if the deceased had attained the Honorary Degrees.
4. Make certain that the Service of Tribute book which is to be presented to the family is filled out properly.
5. **A proper eulogy should be given.** The following subjects should be covered: Moose History (length of membership, service to the lodge and other units of the Order), service to the Community and Church and mention of survivors, wife, children, etc.
6. Flowers should be placed in flower sheath. Use sheath which is applicable to member's status, Pilgrim, Fellow, Moose Legionnaire or Member, seal with tab and place on podium in advance. Discard all other flower sheaths.
7. By eliminating the reference to placing the flowers upon the casket, this same service can be used as a Memorial Service or a Cremation Service.
8. Use the following diagram, if space permits, at the Funeral Home.

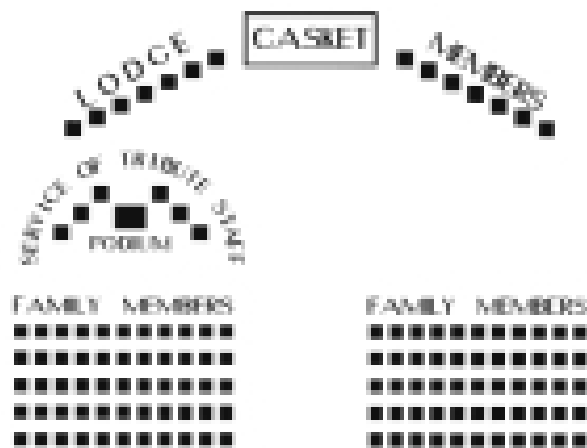

**DIAGRAM NO. 3**

**MODERATOR** - In memory of a departed Brother, members of the Loyal Order of Moose perform a service of tribute if requested by the family of the departed. We will now proceed with the Service of Tribute for Brother \_\_\_\_\_.

**GOVERNOR** -

*The Lord is my shepherd, I shall not want.  
He makes me lie down in green pastures;  
He leads me beside quiet waters.  
He restores my soul; He guides me  
In the paths of righteousness  
for His name's sake.*

*Even though I walk through the valley of death,  
I fear no evil; for Thou art with me;  
Thy rod and Thy staff, they comfort me.  
Thou dost prepare a table before me in the  
Presence of my enemies;  
Thou has anointed my head with oil;  
My cup overflows.  
Surely goodness and loving kindness  
Will follow me all the days of my life.  
And I will dwell in the house of the Lord forever.*

(PSALM 23)

**PRELATE**- Let us pray.

Almighty Father, we are reminded of the frailty of human life, for we have again been called into the presence of death. One of our Brothers has been called from this life, and our Defending Circle is broken. To our mortal vision, all around us is darkness, and so we turn to You, Source of all life and light, for comfort and for aid. Help us realize our dependence upon You. Help us today as we share this loss of our Brother, that we may comfort his loved ones. Help us to assure them of Your wisdom and Your loving-kindness, that they may say with us: Thy will be done. Amen.

**EULOGY —**

**JUNIOR GOVERNOR** - Our Defending Circle is broken. Its goal was Brotherhood: we built a great fraternal society and in it saw the realization of our goal. We placed each member in the Defending Circle of Protection, a Circle that would shield those within. Only yesterday we let our thoughts dwell on that Circle, and our hearts felt pride and exaltation, but today the Circle is broken and we stand helpless in the presence of death. Today, we realize how temporary is the life of man. Now we can only pray that You who watch over us will forgive our mistakes and faults, and that You will, because of the dedication that built it, find our Circle worthy.

**PAST GOVERNOR** - Yes, our Defending Circle is broken. Nevertheless, our departed Brother shall continue to be in our thoughts. God in His wisdom gives to us the ability to remember those who have left this life. He also helps us to realize that through faith and devotion to Him, eternal life is possible. The example of this Brothers' service shall be appreciated forever.

Yes, he has now passed from this life into eternity. But, he shall continue to live in our thoughts. We remember him as he stood in our Defending Circle proclaiming his dedication to Brotherly kindness that would unite all mankind in this life.

**GOVERNOR** - Death is not to be feared. Our Heavenly Father is the author of life and all that is in it. Death provides us with a peaceful sleep. It is a great mercy, a peaceful rest from the struggles of life. May our Brother rest in peace.

Death is but a separation, a journey to an unknown shore, a journey which we too must take - when this life has reached its end.

**PRELATE** - Let us pray.

Heavenly Father, we come to You in this hour of sorrow. May Your tenderness and compassion touch the hearts of all who have gathered here, especially the family of our departed Brother. Comfort us in our sorrow and revive our trust and faith in You. Oh Heavenly Father, help us to conform our lives to Your divine will, that we may exemplify Your good works and glorify Your name. Give us the strength to bear this burden Your wisdom has placed upon us, and make us strong to battle with the temptations and struggles of this life, so that when our day has come, we too may be gathered into Your presence.

This we ask in Your name. Amen.

**GOVERNOR** - Now, Oh Heavenly Father, with these flowers, symbols of immortality, we commit our Brother to Your loving care. (Lay flowers on the casket.)

*(If appropriate, Tribute Staff and Members file past family to express sympathy.)*

## SPECIAL GRAVESIDE SERVICE

*(If desired by the family, members of the Moose Lodge may officiate at a Graveside Service for a departed Brother. The following service may be used at the graveside.)*

*(Governor, Committee and Members shall form Circle as before.)*

**GOVERNOR** - We have come to this place for the purpose of committing the earthly remains of our brother \_\_\_\_\_ name \_\_\_\_\_ to their final rest. Though \_\_\_\_\_ name \_\_\_\_\_ has passed from this life, his memory remains in our hearts and in our actions.

Dear family and friends, we share in your sorrow and loss. Though the burden that you carry is great, we hope that you will find comfort in boundless divine compassion and in the knowledge that we are dedicated to caring for you in this time of need.

**PRELATE** - Heavenly Father, we turn to You in this time of loss and ask that Your tenderness and compassion might touch the hearts of us all, especially the family or our Brother \_\_\_\_\_ name \_\_\_\_\_. We pray that You will ease our sorrow with Your comfort. Help us to see this burden as an opportunity to turn to You with faith and trust, seeking the strength that only You can provide. Amen.

Now, Heavenly Father, with these flowers that symbolize immortality, we commit the body of our brother \_\_\_\_\_ name \_\_\_\_\_ to Your tender care.

*(Lodge members and family deposit flowers on the grave.)*

**GOVERNOR** - Dear friends, our Brother lies at rest. But,

may we leave this place with the hope that one day we will meet again and once more make complete our circle that is broken today. Until then, we bid our Brother farewell.

**MEMBERS** - Farewell.

*(Everyone departs the graveside in an orderly fashion, marching in single file.)*

## Memorial Service

*Memorial Services shall be held annually, on or about the first Sunday in May of each year. In lodges that have a chapter of the Women of the Moose this should be a joint ceremony, paying respect to departed Brothers and Co-Workers. If the lodge does not have a chapter of the Women of the Moose references to the Women of the Moose should be deleted when the Memorial Service is performed. Every attempt should be made to notify the relatives of departed members and co-workers of the date and hour at which the Memorial Service is going to be performed.*

*The charter of the lodge and chapter will be placed on easels near the Governor's station (see diagram). The Altar and stations will be placed as at a regular men's lodge meeting, with the addition of chairs for the officers of the chapter alongside of the lodge officers chairs. The Governor will call the meeting to order at the appointed time by giving one rap with the gavel.*

**GOVERNOR** - (*Gives one rap.*) Dear friends, we have gathered here in this place, at this hour for the purpose of remembering and honoring those Brothers and Co-workers who have been called from the Defending Circle of our Order in the past year. Brother Sergeant-at-Arms and Guide please drape our table with a cloth of black, which signifies our sorrow in the loss of our departed Brothers and Co-workers.

*(Sergeant-at-Arms and Guide follow instruction and then return to their chairs.)*

**GOVERNOR** - (*Gives two raps.*) Dear friends will you please rise as the Prelate leads us in prayers.

*(Prelate moves to Altar - pos. 1)*

**PRELATE** - Let us fold our arms, and bow our heads. Heavenly Father, today we gather to pay tribute to the memories of our departed Brothers and Co-workers; those of our number called to their eternal rest. Grant that their memory may remain with us forever, and that their example will

inspire us to live nobler lives. We ask You to continue to bless the families and loved ones of these our departed friends. Let all that we say and do here, in this Memorial Service, be acceptable in Your sight. Amen.

**MEMBERS** - *(Respond)* Amen.

*(Appropriate music or song may be used at this time.)*

**GOVERNOR** - Brother Sergeant-at-Arms and Guide please escort the Junior Past Governor and Junior Graduate Regent to the anteroom where they each will receive a bouquet of flowers. *(All four Officers remain in ante room until called upon to return.)*

**GOVERNOR** - Will the Junior Governor and the Junior Regent please come forward and drape their respective charters.

*(Junior Governor and Junior Regent come forward and drape respective charters and are then seated next to charters.)*

**GOVERNOR** - Brother Sergeant-at-Arms and Guide will you please escort the Junior Past Governor and Junior Graduate Regent into the lodge room and bring them to a position in front of the draped charters.

*(Sergeant-at-Arms and Guide return to the lodge room escorting each, carrying a bouquet of flowers, to a place in front of the draped charters.)*

**GOVERNOR** - *(With Senior Regent at his side. Soft appropriate background music may be played during the reading of the names and the presentation of the flowers.)* In loving memory we call the names of those who have departed from our Defending Circle since we have last met.

*(As Governor and Senior Regent read names, the Junior Past*

*Governor and Junior Graduate Regent will hand a flower to the Junior Governor or Junior Regent to place in a white vase setting on a small table in front of charters. A brief response of 2 or 3 sentences may be made by the Governor or Senior Regent concerning honors received by the deceased, immediately after person's name is called.. After names are read, all four will return to stations and are seated.)*

**GOVERNOR** - The memories of those departed Brothers and Co-Workers are treasures to be cherished forever. Today, we have once again assembled to show due respect to these members of our lodge and chapter, who were known and loved by us all.

**SENIOR REGENT** - The natural process of life leads us all inevitably to the reality of death. But, dear Brothers and Co-workers we take great comfort in the fact that many sweet memories remain of those who have departed, and their work accomplished while in our midst.

**GOVERNOR** - Their charity, kindness and generosity we treasure in our hearts. Their fidelity and virtue serve as models for us to follow. Their independence, and courage we acclaim today, and to all. For death serves only to remind us that our time too is fleeting, and that while we live, we remain steadfast to the precepts of our Order.

Today, may we be mindful that life and death must be faced with courage. Today may we be mindful that the exhilaration in life must be balanced with humility and that sadness of death must be balanced with hope.

When we too face the inevitable moment of death, may the faces of those we love and who love us fill our hearts? For it is in the lives that remain, that our spirit lives on.

**GOVERNOR** - (Gives two raps) Dear friends, will you

please rise and stand with folded arms and bowed heads as the Chaplain leads us in prayer.

*(Chaplain moves to Altar position 1)*

**CHAPLAIN** - Divine Father, we thank You for the opportunity we have shared today as You have permitted us to gather in tribute to our departed loved ones. May we continue to recall with admiration and affection their names and may we continue to see through the blessing of memory, their faces. We ask You to continue to bless the families of each departed Brother and Co-worker. Grant us the strength to courageously endure the trials of life. Grant us the wisdom to fearlessly seek You and serve You as long as we live. Amen.

**MEMBERS** - *(Respond)* Amen.

**GOVERNOR** - *(Gives one rap)* Please be seated. On behalf of Lodge \_\_\_\_\_ and Chapter \_\_\_\_\_, we sincerely thank you for joining with us in memory of our departed Brothers and Co-workers. If any family members or loved ones would come forward after the ceremony is concluded we would be honored to present you with a memorial flower, symbolic of the loving memory that we share with you.

*(Governor and Senior Regent will present flowers after meeting is concluded.)*

## FLOOR POSITIONS FOR MEMORIAL SERVICE

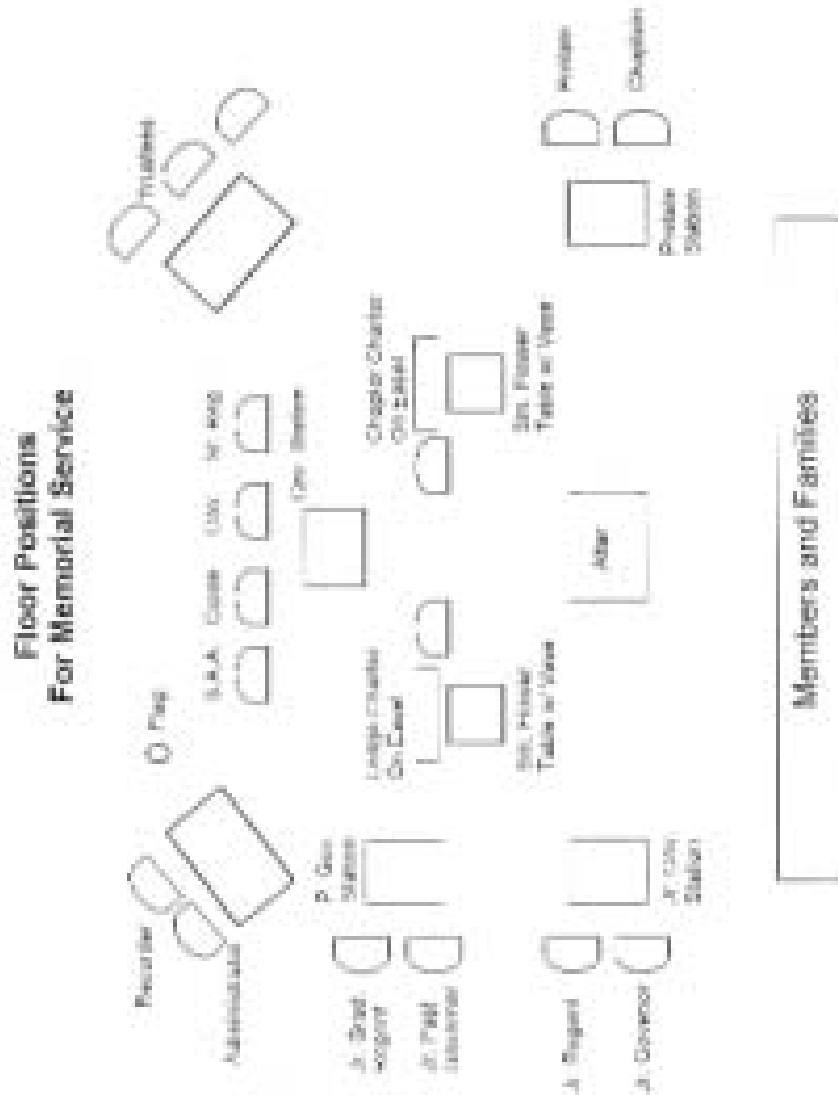

**DIAGRAM NO. 4**

---

## INSTALLATION CEREMONY

Attendance at Installation of Officer's Ceremony is limited to good standing members of the Order. However, family members and honored members of the community may attend at the discretion of the Board of Officers. At the institution of a new Lodge, it is recommended that family members and honored members of the community be invited to attend the Installation of Officers. At all installations, it is permissible to drape the officers' stations, the Altar with its Altar Cloth and to open the Bible. In mid-term, an officer-elect shall be installed by the Installing Officer, who shall use only such portions of the ceremony pertaining to such officer-elect.

The Installation Ceremony shall be held at the last meeting in April of each year, or at a special installation ceremony held prior to April 30th and approved by the Lodge Board of Officers. Newly elected officers will assume office as of midnight April 30th, provided the certificate of good standing, based upon the immediate preceding January 31st report, has been received from the Supreme Lodge. The Jr. Past Governor (who served as such during the past year) shall be the Installing Officer, or, any Past Governor of the Order, appointed by the Governor, may conduct the installation ceremony.

Before the ceremony, the stations and Altar should be as for a regular lodge meeting with the additional chairs as shown in diagram on page 58. The Installing Officer should ensure the Prelate (elect) has a copy of this book for the prayer.

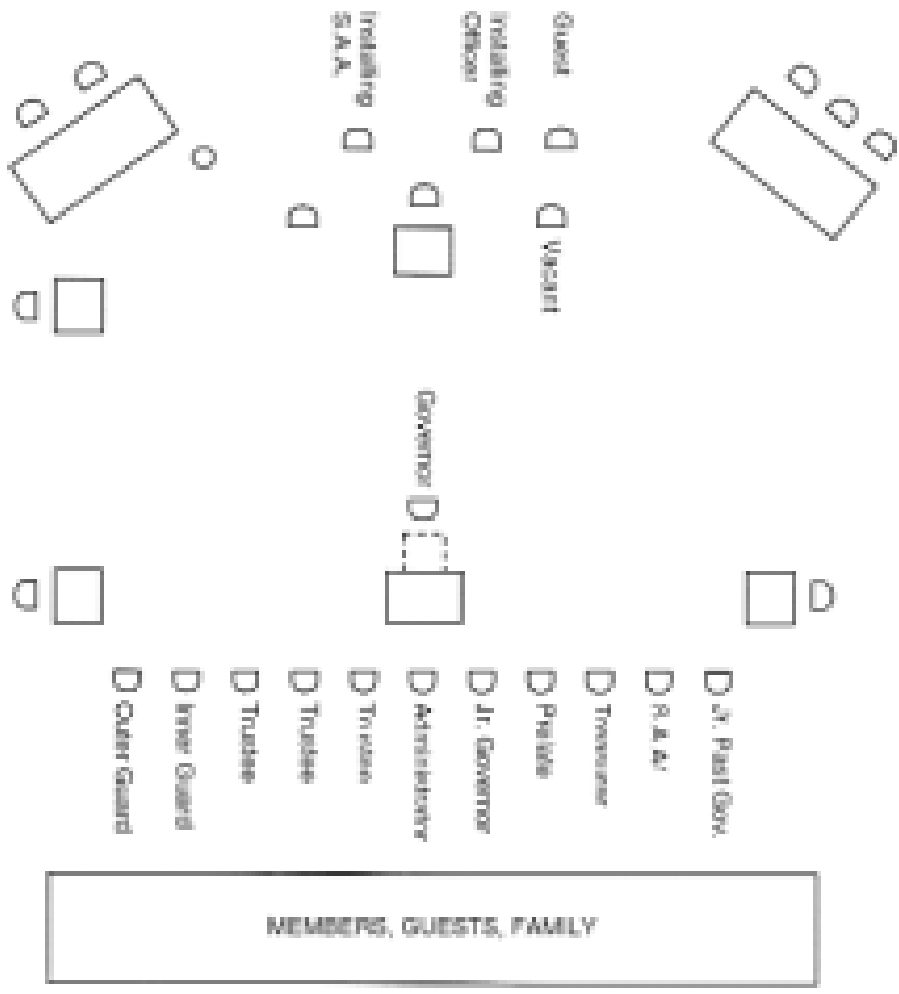

DIAGRAM NO. 5

---

## INSTALLATION CEREMONY

### For Lodge Officers

**GOVERNOR:** *(Gives one rap)* Brothers, it is now time to install your elected and appointed officers. I have the honor of introducing \_\_\_\_\_ (title, if applicable) who will be our Installing Officer.

**GOVERNOR:** *(Gives two raps)* Everyone will please rise.

**GOVERNOR:** Brother \_\_\_\_\_, I hand you the gavel, as a symbol of your authority.

**INSTALLING OFFICER:** *(Gives one rap)* Everyone will please be seated.

*(The Governor takes a seat at the right of the Installing Officer.)*

**INSTALLING OFFICER:** Brothers, I am here for the purpose of installing your elected and appointed officers. Before doing so, it is my duty to determine whether your retiring officers have complied with the Laws of the Order.

Brother Governor, have the Brothers whom \_\_\_\_\_ Lodge No. \_\_\_\_\_ desires to install into office for the current year been elected or appointed in strict compliance with the General Laws of the Order?

**GOVERNOR:** They have.

**INSTALLING OFFICER:** Is the Lodge in good standing with Moose International?

**GOVERNOR:** It is.

**INSTALLING OFFICER:** The retiring officers will vacate their stations.

*(Retiring officers vacate stations.)*

**INSTALLING OFFICER:** At this time it is my pleasure to introduce Brother \_\_\_\_\_, who will be assisting as the Installing Sergeant-at-Arms for the ceremony.

*(Installing Sergeant-at-Arms will take his place at the Altar.)*

**INSTALLING OFFICER:** The Administrator will call the roll of the officers-elected and appointed and, as each officer's name is announced, he will report to the Sergeant-at-Arms at the Altar and be seated as instructed.

*(The officers elected and appointed shall be seated at the Altar, as shown in the diagram.)*

**INSTALLING OFFICER:** Brothers, do any of you have just cause to show why any or all of the officers elected or appointed for this Lodge, should not be installed into office? If so, please make it known at this time.

*(If any cause should be presented which cannot be satisfactorily adjusted, the Installing Officer shall require the elected or appointed officer to retire from his position at the Altar, and, proceed to install the remaining officers. Immediately following the installation, the Board of Officers shall submit a detailed report covering the cause to the General Governor, and await his decision. Pending the decision of the General Governor, the officer who held the office the preceding year shall remain in office. If he is unable or unwilling to continue in this position, the office should remain vacant until a final decision of the General Governor.)*

**INSTALLING OFFICER:** Since there appears to be no objection to any of the officers elected or appointed, I shall proceed to install them.

**INSTALLING OFFICER:** *(Addressing officers elected and appointed)* Do each of you accept the office to which you have been elected or appointed? If so answer I do.

**OFFICERS-ELECT:** I do.

**INSTALLING OFFICER:** Officers elected and appointed will rise. Place your left hand over your heart, raise your right hand, and repeat after me, using you name where I use mine.

I, \_\_\_\_\_, — do solemnly promise — that I will faithfully and to the best of my ability — perform the duties of the office — to which I have been elected or appointed. — I will comply with the Laws of this Order — and the bylaws of this Lodge. I will memorize the portion of the Ritual — pertaining to the office I hold. — I will obey all orders emanating from the Supreme Council,— the officers of the Supreme Lodge — and Moose International. — I will remember that — this Family Fraternity is a private organization — whose privileges belong only to its members. — I will promote the Moose fraternal programs — and work to provide — the many membership privileges — promised to our new members — upon their enrollment. — I will promote and support— the programs of the Moose Legion, — and, I will strive to reach — the level of Moose service — that merits advancement to — the Fellowship and Pilgrim Degrees. — I will help lead my Lodge — toward membership and financial progress. — I will deliver to my successor in office, — or to any other legal authority of the Order, — all funds and property in my possession — belonging to this Lodge — or to any other Lodge of the Order. — I further promise — that I will be a leader by example — in the office to which I was elected or appointed. — To all of which I pledge my honor. You may lower your hands and be seated.

**INSTALLING OFFICER:** Will the retiring officers please rise. Please join me in applauding the time, effort and faithful service they have rendered to the membership of this Lodge and to the Order during the preceding year. Thank you for a job well done!

\* \* \* \* \*

**INSTALLING OFFICER:** Brother Sergeant-at-Arms, present the out-going Governor at this station.

*(Sergeant-at-Arms does as directed.)*

**INSTALLING OFFICER:** Brother \_\_\_\_\_, you have served this Lodge faithfully as the presiding officer. (For new Lodge institutions - Brother \_\_\_\_\_, you have been appointed as the Junior Past Governor of this Lodge.) You are qualified to act as advisor on matters upon which you will be called to speak, and your attendance at Lodge meetings will assure that the good accomplished under your leadership will continue.

As the Junior Past Governor, you will continue as a member of the Lodge Board of Officers, and the House Committee. You will also remain as a member of the Mooseheart/Moosehaven Admissions Committee, always being alert to those in need of our services. You are also the Installing Officer of this Lodge until another has taken your place.

As a Past Governor, you are now entitled to membership in the Supreme Lodge when present at its sessions with proper credentials. I now declare you installed as the Jr. Past Governor of this Lodge and invest you with the emblem of your office. Brother Sergeant-at-Arms, please escort the Jr. Past Governor to his station.

\* \* \* \* \*

*(Omitted if the Outer and Inner Guards  
are not utilized by the Lodge)*

**INSTALLING OFFICER:** Brother Sergeant-at-Arms, present the Outer Guard and Inner Guard at this station.

*(Sergeant-at-Arms does as directed.)*

**INSTALLING OFFICER:** Brothers \_\_\_\_\_, it is your duty to greet each Brother as he enters the Lodge, and to make the members of this Lodge, as well as visiting Brothers, feel a sense of welcome. Likewise, it is your duty to maintain decorum inside and outside the Lodge room door, and, to see that no one but those qualified enter the Lodge room. You shall also perform all other duties required by the Laws and Ritual of the Order. I now invest you with the emblems of your office and declare you duly

installed. Brother Sergeant-at-Arms please escort the Inner and Outer Guards to their stations.

\* \* \* \* \*

**INSTALLING OFFICER:** Brother Sergeant-at-Arms, present the Sergeant-at-Arms at this station.

*(Sergeant-at-Arms does as directed.)*

**INSTALLING OFFICER:** Brother \_\_\_\_\_, you are under the direction of the Governor. You shall assist members, visitors, or latecomers in making proper entry into the Lodge room. You are the custodian of Lodge paraphernalia and shall properly arrange it for all meetings and special functions, and immediately remove the paraphernalia after each function. You shall perform such other duties as may be designated by the Ritual or required by the Governor. I now invest you with the emblem of your office and declare you duly installed as Sergeant-at-Arms. Brother Sergeant-at-Arms, please escort the Sergeant-at-Arms to his station.

\* \* \* \* \*

**INSTALLING OFFICER:** Brother Sergeant-at-Arms, present the Trustee(s)-elect at this station.

*(Sergeant-at-Arms does as directed.)*

**INSTALLING OFFICER:** Brother(s) \_\_\_\_\_, the proper operations of this Lodge will depend on your attention to duty. You shall take an inventory of all physical property of the Lodge once a year and deliver your report to the Governor. You shall examine and approve all bills, and report your recommendations regarding payment to the Lodge and House Committee. You shall compile an inventory of House Committee merchandise for resale monthly, and deliver report to the Administrator. You shall perform all other duties required by the Laws of the Order or by the Lodge. The members of this Lodge are confident in your abilities to perform these special duties. I now invest you

with the emblem(s) of your office and declare you duly installed as Trustee(s) of this Lodge for the term to which you have been elected. Brother Sergeant-at-Arms, please seat our new Trustee(s).

\* \* \* \* \*

**INSTALLING OFFICER:** Brother Sergeant-at-Arms, present the Treasurer-elect at this station.

*(Sergeant-at-Arms does as directed.)*

**INSTALLING OFFICER:** Brother \_\_\_\_\_, you, along with the Administrator and Governor shall be a custodian of all securities. You are the Treasurer of this Lodge Corporation and authorized to sign all checks ordered paid by the Lodge or House Committee. You shall receive from the Administrator all deposit slips showing deposits made by him in financial institutions in the name of the Lodge, and report this information to the membership at regular meetings. You can ensure the confidence that the members have placed in you by performing your duties with the utmost care and fidelity. I now invest you with the emblem of your office and declare you installed as Treasurer. Brother Sergeant-at-Arms, please escort the Treasurer to his desk.

\* \* \* \* \*

*(IF THE ADMINISTRATOR HAS NOT BEEN PREVIOUSLY INSTALLED.)*

**INSTALLING OFFICER:** Brother Sergeant-at-Arms, present the Administrator-elect at this station.

*(Sergeant-at-Arms does as directed.)*

**INSTALLING OFFICER:** Brother \_\_\_\_\_, you are the Secretary of this Lodge Corporation, and along with the Treasurer and Governor, are a custodian for the securities of this Lodge. You shall correctly keep minutes of all meetings of this Lodge and House Committee, maintain

accurate financial reports, preserve and file all valuable papers, report all membership records as required, sign all approved checks and legal documents, and read all correspondence to the Board of Officers, House Committee and Lodge. You shall make timely Certified Reports to Moose International and perform all other duties as required by the laws and ritual of the Order. Carefully study all the Laws of the Order, insist your books be audited quarterly by the Auditing Committee, be zealous in your efforts to keep this Lodge in good standing in the Order, so the members may be entitled to the protection provided. As correspondent for the Mooseheart/Moosehaven Admissions Committee, your promptness in communicating with Moose International is of vital importance. Believing your ability and zeal in the discharge of your duties will contribute to the success and prosperity of this Lodge, I present you with the emblem of your office and declare you duly installed as Administrator. Brother Sergeant-at-Arms, please escort the Administrator to his desk.

\* \* \* \* \*

**INSTALLING OFFICER:** Brother Sergeant-at-Arms, present the Prelate-elect at this station.

*(Sergeant-at-Arms does as directed.)*

**INSTALLING OFFICER:** Brother \_\_\_\_\_, you are a member of the House Committee and the Auditing Committee, and shall perform all other duties as required by the Laws and Ritual of our Order. It will be your duty to invoke the blessing of the Supreme Being in our services and ceremonies. You will promptly contact or visit the sick and be as helpful as possible to the needy and distressed and make a report at each Lodge meeting. Let your conduct and demeanor be such as to instill the spirit of purity, providing an example for all members to follow. I now present you

with the emblem of your office and declare you duly installed as Prelate. Brother Sergeant-at-Arms, please escort the Prelate to his station.

\* \* \* \* \*

**INSTALLING OFFICER:** Brother Sergeant-at-Arms, present the Junior Governor-elect at this station.

*(Sergeant-at-Arms does as directed.)*

**INSTALLING OFFICER:** Brother \_\_\_\_\_, you are Vice-President of the Lodge Corporation, a member of the House Committee and shall perform all duties required of you by the Laws and Rituals of the Order. You will assist the Governor in preserving order and decorum in the Lodge, and in conjunction with him, inspect all votes on applicants when warranted. In the absence of the Governor, you will preside over the deliberations of this Lodge with full authority to perform his duties and responsibilities. You will be a member of the Mooseheart/Moosehaven Admissions Committee, and shall be alert at all times for those in need of the program. It is with pleasure that I invest you with the emblem of your office and declare you duly installed as Junior Governor. Brother Sergeant-at-Arms, please escort the Junior Governor to his station

\* \* \* \* \*

**INSTALLING OFFICER:** Brother Sergeant-at-Arms, present the Governor-elect at this station.

*(Sergeant-at-Arms does as directed.)*

**INSTALLING OFFICER:** Brother \_\_\_\_\_, I welcome you to the station of Progress. You are the President of the Lodge Corporation and shall preside at all meetings of the Lodge and House Committee. It shall be your duty to preserve order, apply and enforce all the Laws of the Order, and decide parliamentary questions. You,

along with the Administrator and Treasurer, are a custodian of all securities and authorized to sign all approved checks. You are a member of all committees of the Lodge, and you must, at the first regular Lodge meeting, appoint the chairman of all prescribed standing committees. While you are Governor, this Lodge should show an increase in good standing membership and an increase in net assets. Listen with respect to the opinion of your Brothers, and in making decisions, remember that your own feelings or interests must have no weight. The Lodge membership should be harmonious, diligently promoting our purposes, and enthusiastically engaged in furthering our Fraternal objectives. As chairman of the Mooseheart/Moosehaven Admissions Committee, be ever alert for those who may be in need of these special services. Upon completion of your term of office, you become a Past Governor of this Lodge, which entitles you to membership in the Supreme Lodge when present at its sessions with proper credentials. A distinctive honor has been conferred upon you by the members of your Lodge, and it is my pleasure to now invest you with the emblem of your office. I declare you duly installed as Governor of this Lodge. Brother Sergeant-at-Arms, please escort the Governor to a place on my left.

*(Governor stands at left of Installing Officer.)*

**INSTALLING OFFICER:** By the authority vested in me as Installing Officer, I now declare the officers of this Lodge duly installed.

*(Installing Sergeant-at-Arms returns to his chair and remains standing.)*

**INSTALLING OFFICER:** *(Gives two raps.)* Everyone will rise. Brother Prelate, you will ask the blessing of the Supreme Being.

**PRELATE:** *(At Altar)* Let us fold our arms and bow our heads. Supreme Being, we ask You to watch over these officers, to whom the leadership of this Lodge has been

committed. Implant in their hearts the spirit of Fraternal service, instill wisdom into their decision making, and direct them toward greater contributions to the humanitarian efforts of our Order. We especially ask for peace and harmony to prevail in this Lodge, and that prosperity and good health be granted to every individual member and his family. We ask these things in Your name. Amen.

**MEMBERS:** *(in concert)* Amen

*(Prelate returns to station)*

**INSTALLING OFFICER:** Brother Governor, I now present to you the gavel, the symbol of your authority. *(Hands gavel to Governor)* Never let it fall in anger, but wield it firmly and with discretion.

**INSTALLING OFFICER:** Brothers, let us greet our new Governor with a round of applause.

**GOVERNOR:** *(Gives one rap)* Everyone will be seated.

*(Installing Officer returns to his chair and is seated and governor proceeds with the regular order of business, or with the program.)*

### MOOSEHEART FOUNDERS DAY CEREMONY

The ceremony may be performed as a separate occasion, or it can become part of an Enrollment Ceremony dedicated to this occasion. The Women of the Moose, Moose members, families and qualified guests should be invited to attend this function.

*(The Mooseheart Founders Day Ceremony shall be held annually, on or about October 27th of each year.)*

*(Participants may comprise the Officers of the lodge, the members of the Ritual Staff or other members of the lodge selected by the Governor to serve in this particular capacity. The participants should be appropriately dressed. If the Ritual Staff performs, they should be in their uniform dress.)*

*(If held as a special ceremony, see page 16 for Opening Ceremony. If held in conjunction with an Enrollment Ceremony, use instead of Guest speaker.)*

GOVERNOR: At this time we would like to pay honor to James J. Davis, the Founder of Mooseheart, with the following ceremony. *(If done by Lodge Officers continue to Ceremonial parts.)* The Ceremonial Staff will take their positions.

*(Lodge Officers will vacate the stations as Ceremonial Staff takes their positions.)*

CEREMONIAL GOVERNOR: Officers and members of \_\_\_\_\_ Lodge No. \_\_\_\_\_ Loyal Order of Moose, Women of the Moose and friends. Throughout our Order, October 27th of each year is recognized as Mooseheart Founders Day. This day has been set apart to properly celebrate with joy and thanksgiving the birth, growth and progress of our Child City, to recognize its service to childhood through the years since 1913, and to remember with gratitude those who served so well in the founding of Mooseheart.

October 27th is the birth date of the principal founder of Mooseheart and the Order's first Director General, James J. Davis.

Brother \_\_\_\_\_ will tell us of the man whose vision of many years ago is the foundation of our Fraternity today.

CEREMONIAL PAST GOVERNOR: James J. Davis was born in Wales on October 27th, 1873. His accomplishments in later life were molded and shaped through his early childhood experiences in a home of very limited means. From this spartan beginning, our first Director General grew to become one of the great humanitarians of his era.

In 1881, Davis's parents left Wales and settled in Pittsburgh, Pennsylvania, where his father found employment in the steel mills. At the age of 11, James J. Davis began work as his father's assistant in the iron and steel mills of Sharon, Pennsylvania, qualifying as a steel puddler. In 1893, at age 20, he moved to Elwood, Indiana, to work in a tinplating mill.

James Davis soon became active in the labor movement and his compassion for others began to surface. Well respected by all that associated with him, Davis was urged to run for public office. He was first elected as City Clerk of Elwood, Indiana, and then as County Recorder in 1902.

1906 opened another era in the life of James J. Davis. He became a member of the Loyal Order of Moose. Just one year later he was elected the Fraternity's first General Dictator or "Director General" as we know the title today. Through James J. Davis' strong leadership, and his desire to establish programs vital to his fellow men, the Fraternity grew from just a few hundred members in 1907 to over seven hundred and fifty thousand at the time of his death in 1947.

Others recognized James J. Davis' talents. He was appointed as Secretary of Labor in 1921 and served in this capacity under three presidents. Davis was elected to the United States Senate in 1930 and served until his retirement in 1945.

CEREMONIAL GOVERNOR: Brother \_\_\_\_\_, the vision of James J. Davis was to establish a "Child City" where the children of deceased Moose Members could find shelter and refuge. Please relate to us the results of this vision.

CEREMONIAL JUNIOR GOVERNOR: The idea of a school

for the sons and daughters of members of the Loyal Order of Moose was first presented at the twenty-second annual convention of the Fraternity held in Baltimore, Maryland, in 1910. Although at that time the plans were in a comparatively undeveloped state, this bold new concept was given the unanimous approval of the delegates. This undertaking was an innovation in the annals of Fraternalism, but well in line with its efforts to provide the greatest good for the greatest number.

James J. Davis' first thoughts of a "Child City" went beyond the scope of just feeding and clothing the children of deceased Moose members. James J. Davis felt that the children must be educated; they must be trained so that when they graduate from high school they may take care of themselves, they may have a chance equal to other young men and women.

Our "Child City" had a humble beginning. Mooseheart was dedicated under a rented circus tent on July 27th, 1913. The dream of James J. Davis then and there became a reality because it was well planned and executed. Yes, with his foresight, Mooseheart grew from a cornfield to a modern City of Children, nestling as it does in the beautiful Fox River Valley of Northern Illinois. Mooseheart is the crowning achievement of James J. Davis and the many stalwart men and women who since have dedicated themselves to the Loyal Order of Moose and the Women of the Moose.

As you visit the Mooseheart Campus, there is the sense that here is a setting where children can breathe, move and live in the clean spaciousness which God created for all His creatures.

We have made tremendous progress since this humble beginning, and as our Fraternity has grown in numbers and in strength, so shall Mooseheart grow to accommodate those children who come to us in the future.

**CEREMONIAL GOVERNOR:** The career of James J. Davis is typical of the opportunities afforded to free men in a free country. He grew to manhood in an environment where character and strength of purpose, combined with desire to serve others, paved the way for accomplishments for which he will

remembered for all time.

Brother \_\_\_\_\_ will enlighten us with the vision of a promise.

PRELATE: The promise is made to every member of the Loyal Order of Moose that we shall conduct ourselves at all times as an organization with a profound belief in a Supreme Being. To this end, we have built at the Child City of Mooseheart a great church known as the House of God, administering equally to all faiths, allowing each child there to worship in the religious belief that prevailed in his own home before coming to Mooseheart. It is altogether fitting, therefore, that we begin to close this ceremony with prayer. Everyone please rise. Let us fold our arms and bow our heads.

"Our Heavenly Father, we give thanks to You for allowing us to congregate to joyfully remember the founding of the Child City of Mooseheart, and to recount those many blessings bestowed upon us during our years of service to childhood. Bless each home represented here on this occasion, and may those homes endure in happiness and contentment without the necessity of Mooseheart's services ever arising. May we leave this meeting with a special prayer that You will continue to keep Mooseheart in the hollow of Your hand. Bless us now as we go our several ways. Amen."

CEREMONIAL GOVERNOR: *(Raps the gavel once)*  
Everyone please be seated. We have learned much of the founding, the history, and the purpose of Mooseheart. The observance of Mooseheart Founders Day is a renewal of our devotion to the ideals and precepts of the Loyal Order of Moose. We appreciate your attention, and hope you have gained a new understanding of our Fraternity.

*(If done by a Ceremonial Staff they vacate the stations and Lodge Officers return.)*

*(Governor should thank the Ceremonial staff and have the Ceremonial Governor introduce them if it has not already been done.)*

***(Turn to page 27 to close the meeting.)***